

Fundamentals of Filament Interaction

Final Progress Report

Report Period: 08/01/2011--07/31/2016

Grant Contract #: FA95501110001

Principal Investigator:

M. Richardson,

Townes Laser Institute, College of Optics & Photonics, University of Central Florida
P.O Box 162700, 4000 Central Florida Blvd., Orlando, FL 32816-2700

mcr@creol.ucf.edu

Co- Principal Investigators

M. Baudelet

Townes Laser Institute, College of Optics & Photonics, University of Central Florida
P.O Box 162700, 4000 Central Florida Blvd. Orlando, FL 32816-2700

Tamar Seiderman

| Ryan Hall | Office #4016

Department Of Chemistry 2145 Sheridan Road • Evanston, Il 60208-3113

Phone 847-467-4979 • Fax 847-467-4996 • E-Mail T-Seideman@Northwestern.Edu

Prepared by M. Richardson
University of Central Florida

Submitted: May 12, 2017

1.0 INTRODUCTION

This report summarizes the progress made over the five year AFOSR/JTO program on Fundamentals of Filament Interaction. This program for the first three years kept fairly strictly to the research plan outlined in the original proposal. To our knowledge this was the first time the HEL JTO had used an MRI to advance the understanding of optical filamentation in air by ultrashort laser pulses. Studies of filamentation involve many aspects and disciplines, and at that time our laboratory, the Laser Plasma Laboratory (LPL) was studying many of them. Schematically, these are shown in the figure adjacent. The focus of this MRI was very specific. Based in on our other studies we focused this MRI program in two very important areas –filament interaction with gases, and filament interaction with solids. Firstly the common theme of ‘interact’ was more relevant to JTO’s general directions, in that it has a mandate to cover lethality and other related topics. We did not see many lethality issues associated with filament interaction with gases. Rather, by tying the general theme of the proposal, and at the same time injecting a focus towards gases, we could highlight a issue which at the time of the award, was only beginning to raise itself in the filamentation field. This was issues related to molecular orientation, polarization, fluorescence and molecular revival. These were all topics that we could associate with ‘filament interaction with molecular gases’. For this reason we engaged with Tamar Seiderman and her group at Northwestern University, who is a recognized analytical theorist on molecular rotation in gases.

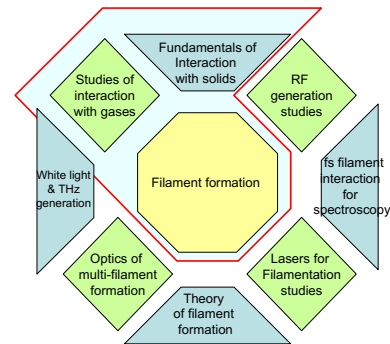

The other side of the filament interaction issue, with solids, we were well aware of at the time – and we clearly recognized the relevance to JTO and DoD programs. At that time, we had performed interaction experiments examining the shockwaves generated in transparent media by the interaction of single filaments at ranges of ~ 30 m. This plasma interaction, illustrated by the shock wave image taken with a fs visible probe beam some 21 ns after the interaction of a single filament having a base width of $\sim 400 \mu\text{m}$ interacting with a vertical interface between a thin slab of glass and air, the filament coming from the left-hand direction. The energy in the filament was 8 mJ.

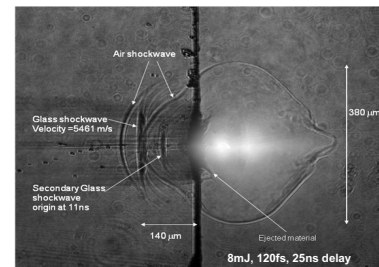

One can clearly see the shock wave in air propagating from the plasma to the right, and even the vestiges of the thermal cylindrical wave propagating outward from the filament itself. Inside the glass medium one see an almost planar shock propagating to the left from the plasma disturbance at the interface. Light that propagates around the plasma generated at the interface is seen to self-focus very quickly in the glass material. On targets where the propagation distance in the glass was finite, this ‘remanence’ light from the original filament, was sufficient such that we it exited the second glass surface, its power was sufficient for it to form a new filament. Thus if the transparent material had the form of a window, the filament was would be able to reform on its back side and propagate as a new filament. This property has significant implications for DoD applications. A second surprising property has also interested several DoD agency personnel. The plasma formed at the interface was created by a sharply rising laser pulse having a rise time of a few femtoseconds, rising to an intensity of greater than $3 \times 10^{13} \text{ W/cm}^2$. These intensities are

great enough to create a plasma with an electron-density n_e higher than the critical density n_c defined as,

$$n_c = \frac{4\pi^2 c^2 \epsilon_0 m_e}{e^2 \lambda^2}$$

where m_e and e are the electron mass and charge respectively, ϵ_0 is the permittivity of free space, c the velocity of light in free space, and λ the wavelength of the laser light. Laser light that reaches the critical density in the micro-plasma formed at the interface serves to drive liberated electrons to very high velocities. In the plasma physics community these are referred to as superthermal or collisionless electrons because their effective temperature is very much higher than that if the small amount of energy in the laser pulse were thermalized with the ions and electrons in the plasma. It is worth noting that at 10^{11} Wcm⁻²

for 1 μ m laser wavelength (Nd)

the oscillation amplitude is equal to the Bohr radius. These high energy electrons stream rapidly away from the parent ions, creating an intense transient Coulomb current. This localized current creates an electric dipole that efficiently radiates RF emission with a characteristic angular distribution. We have made preliminary characterizations of the amplitude and frequency of this RF emission. One sample of this RF emission observed close to a target irradiated at 30 m by a single filament beam, is shown in the figure adjacent.

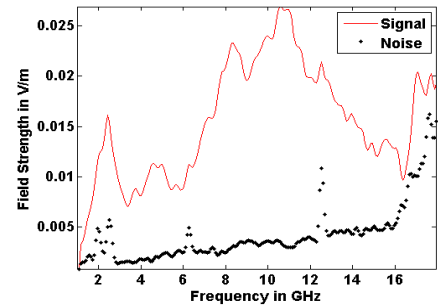

2.0 OUTCOMES OF THE FIRST THREE YEARS OF THE PROJECT.

2.0.0 Program on Interaction with Gases

2.1.0 Molecular alignment studies

Following the observations by Béjot *et al.* [Optics Express 16, 7564 (2008)] and Chen *et al.* [Optics Letters 33, 2731 (2008)] of the filament being a birefringent medium, the importance of the orientation of the molecules in the propagation medium by the pulse became manifest. Following these studies, See-Leang Chin's group in collaboration with Tamar Seideman made a large set of measurements in nitrogen and argon to put in evidence the molecular alignment and rotational revival of the molecules during and after the pulse. Molecular interactions between the filament and the medium have shown several fundamental properties such as (i) pulse shortening to a few cycles, (ii) extension of the super-continuum generation, (iii) spectral modulation, (iv) prolongation of the filament.

These studies raised a multitude of questions that this MRI program is targeting:

- How does alignment affect the filamentation?
- How does the filament affect the medium alignment?

2.1.1 Filamentation in an aligned molecular gas: CO₂

a. Choice of CO₂

The filamentation of ultra-short pulses in a pre-aligned molecular gas is the first project planned in the first year of the MRI program. As mentioned above, the majority of studies have worked on the effect of the filamentation on the propagation medium and the alignment of this gas by the filament. Few studies have explored the effect of a pre-aligned molecular gas on the filamentation process. Nitrogen, oxygen and argon are gases of intense attention but our attention is on carbon dioxide. CO₂ has several advantages as the propagation medium for filamentation:

- Application interest:
 - Atmospheric gas (4th gas in concentration: 390ppmv)
 - Role in atmospheric propagation window
 - Sensing
- Fundamental interest:
 - No extensive studies of laser filamentation
 - 3 modes of vibration (2 Infrared + 1 Raman)
- Practical interest:
 - Gas phase at room temperature
 - Possible to increase pressure for larger effect from CO₂

As a result, CO₂ has been chosen as a model molecule for this project of the MRI program.

As a conclusion from the results of the previous years of research under the MRI, not only the filament can be used as a probe of molecular alignment (temporal features) but is sensitive to the decay of the wavepacket function. One of the advantages of studying CO₂ molecules, over N₂ or O₂, is its long rotational period of ~42 ps versus their 8.3 and 11.6 ps rotational periods respectively. The long rotational period allows one to investigate both the population decay and the revival events coherence of the nonadiabatic alignment. The metric for the amount of alignment, $\langle \cos^2\theta \rangle$, consist of the two components $\langle \cos^2\theta \rangle_p$ and $\langle \cos^2\theta \rangle_c$. $\langle \cos^2\theta \rangle_p$ is related to the population decay of the molecules. $\langle \cos^2\theta \rangle_p$ in a gas at equilibrium will have a value of 1/3. This value is the baseline value for the amount of alignment. $\langle \cos^2\theta \rangle_c$ measures the coherence between the revival events. $\langle \cos^2\theta \rangle_c$ is zero when a medium is in equilibrium. The decay rates for both of these factors are governed by the system's inelastic collisions [T. Seideman 2006].

Analyzing the simulations allows one to extract the decay rates for both population decay and the coherence decay rate between the revival events. By ignoring the revival events one is able to study the population decay. The theoretically determined population decay rate, τ_p , observed leads to a nearly exponential decay rate. The decay rate was determined by fitting the baseline with an exponential decay. From examining the simulation baseline, τ_p of the CO₂ molecules was found to be 64.2 ps. This result is in agreement with the published M-independent theoretical work by Th. Vieillard (2013) and J.-M. Hartmann (2012). In order to compare the population decay, the revival events were removed from the experimental results. The remaining averaged baseline was fit with an exponential decay to

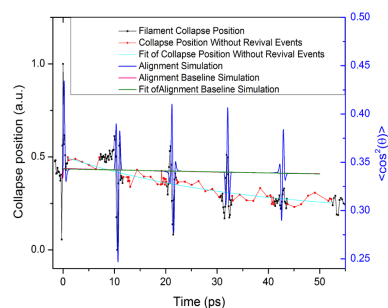

Fig 1. Comparison of the theoretical population decay and experimental collapse position decay

compare it to the theoretical result, figure 30. From the experimental data, the population decay rate was determined to be 33.3 ± 8.4 ps. The experimental decay rate is nearly half of the theoretically determined decay rate. There are several factors that may have led to the factor ~ 2 mismatch. It was expected that the experimental results would decay faster due to the dissipative effects of the plasma. The collision rates used for CO₂ were from empirical data. The collision rates used in the simulation come from experimental results in much less dissipative environments. Also, the simulation did not take into account the anisotropic ionization for CO₂. For a better experimental determination of the population decay more revival events can be probed. It may be possible to investigate revivals up to ~ 150 ps [J.-M. Hartmann 2012]. The number of revival events that can be measured, regardless of the method, is dependent on the time scale of the system to return to equilibrium. Equilibrium conditions are obtained after about 1 ns for CO₂ [J.-M. Hartmann 2012].

The other component of the total $\langle \cos 2\theta \rangle$ is linked to the coherence between the revival events. The dynamics from the laser induced nonadiabatic alignment result from the dephasing and rephasing of the rotational coherences. They were determined by the time evolution of the off-diagonal terms of the density matrix [T. Seideman 2006]. The coherence between the revival events decay rate, τ_c , can be extracted from the simulation. The τ_c is equal to the ratio of (t_1/t_s) , where $t_s = \ln(y_1/y_0)$. y_1 is the value without decay, and y_0 the value due to the decay after a time of t_1 . This leads to a coherence decay rate of 58 ps. Note that the population and decoherence rates are similar, 64 and 58 ps, for the simulation. This similarity is expected from an M-independent calculation [Th. Vieillard 2013]. The decoherence rate was not able to be determined from the experimental results. It may have been possible to extract information about the coherence if later revival events were also measured. It has been recommended that high density/pressure studies could allow one to obtain information on the population decay and decoherence effects independently [T. Seideman 2006, Th. Vieillard 2013]. The disadvantage of a high density study is that the M-independent model is no longer valid. Comparing the M-independent and M-dependent theories of nonadiabatic alignment of CO₂ at 20 bar the M-independent theory fails to reproduce experimental data, figure 31 [Th. Vieillard 2013]. Therefore, the computation of the simulations would have to include the M-dependence to be of use at high pressure. Experimentally, a high pressure environment would yield an increased index of refraction. This increase would support filamentation at much lower energies. The high density thus may impose a limit to the intensity used to align the molecules without ionization.

2.2.0 Precision Characterization of filament intensity distribution

The plasma created along the propagation axis of a filament is generally considered as a signature of filamentation. However, a large range of electronic densities have been reported (10^{12} cm⁻³ to 10^{18} cm⁻³) [Chen 10, Yang 02, Chien 00, La F 99, Tzor 00, Schi 99]. To explain this spread in the measurements, Théberge, *et. al* [Thé 06] studied the influence of external focusing on the density and diameter of the filament-induced plasma column. They found that the plasma density could be increased by four orders of magnitude, with respect to the non-focused case, by using a 10 cm

focal length lens. Based on a semi-empirical model of tunneling ionization, they suggested this difference in the plasma density was the result of a $3 \times$ difference in the filament core irradiance.

With the precise characterization technique developed by the UCF team, we could show that not only the filament core is influenced by external focusing but also the filament fluence profile and the surrounding energy reservoir. In contrast to previous measurements of the nitrogen emission [Thé 06], these measurements of the relative fluence profile of the filament core and surrounding energy reservoir show a greater spatial extent and are consistent with the dimensions of filament-induced ablation of semiconductors [Weid 12].

The laser system used in these experiments was a Ti:sapphire laser centered at 800 nm and amplified through chirp pulse amplification (CPA) within both regenerative and double-pass amplifiers to provide 23.8 mJ (2.26 % Root-Mean-Square (RMS) and 14.66 % Peak-to-Peak (PTP) fluctuations) pulses in 48 fs at a repetition rate of 10 Hz. Further system details are given in Ref. [Weid 09].

The optical system allowing the precise characterization of the filament relative fluence profile is shown in Fig. 2. It consists of a series of fused silica glass wedges arranged at decreasing angles of incidence to progressively attenuate the filament for 1:1 imaging with a CCD camera (DMK72BUC02, Imaging Source). The system images the 800 nm spectral content of the filament while blocking the visible and infrared light using an 800 nm dielectric mirror and band-pass filter (Edmund Optics #67-848) with 40 nm bandwidth.

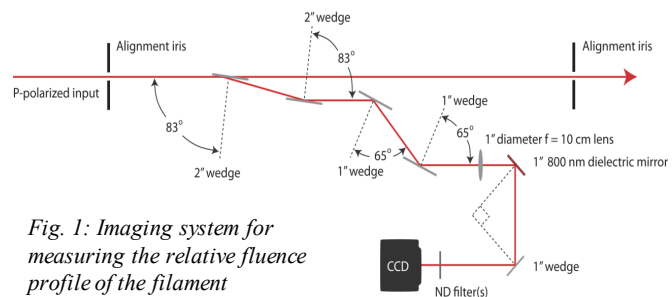

Fig. 1: Imaging system for measuring the relative fluence profile of the filament

Without external focusing, the full beam energy (23.8 mJ) resulted in filament formation starting 3 m from the laser and continued over the remaining 8 m of laboratory space. The addition of an $f = 10$ m lens positioned 2 m from the laser output, resulted in filamentation over a similar distance with only 12.4 mJ. For a constant position of the filament imaging system (Fig. 1) 10 m from the laser, an external focusing with an $f = 1$ m lens was placed 9 m from the laser and measurement was performed using 10.2 mJ. The resulting filament was imaged 101.5 cm from the lens. In all three cases, the minimum pulse duration was used and only one filament was observed using the filament imaging system.

We observed that, with respect to the non-focused case, a focusing lens can increase the peak fluence of the filament, an increase of $\sim 1.8 \times$ when using a 10 m lens and $\sim 18 \times$ when using a 1 m lens (Fig. 2). The shape of the fluence profile is also affected. Although similar Full Width at Half Maximum (FWHM) diameters (279 μm and 282 μm) were observed for the 10 m lens focusing case as compared with non-focused, the diameter decreased (41 μm) when a 1 m lens

was used. Here, in the case of 1 m lens focusing, the transition between filament and energy reservoir was unclear, within the dynamic range of our imaging system. To account for shot-to-shot variation in the filament profiles, 29 single shot measurements were used to calculate the average and 1σ standard deviation. These are depicted by the solid line and surrounding shaded region in Fig. 3(a-c).

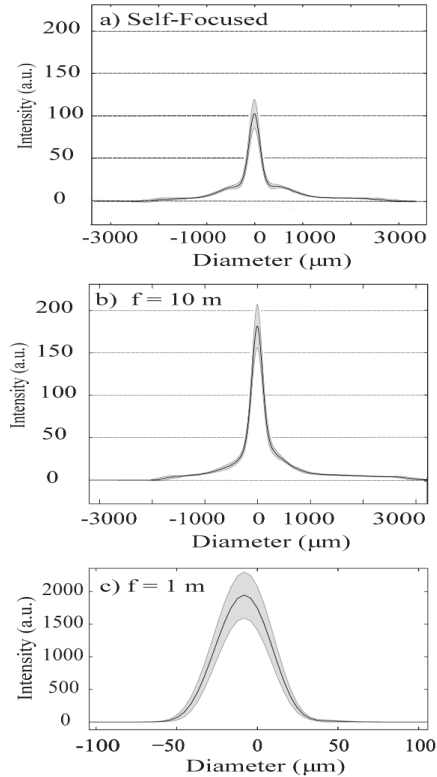

Fig. 3: Relative fluence profile of the filament: comparison between non-focused (a), focused using a 10 m focal length lens (b) and focused with a 1 m focal length lens (c). Average and standard deviation are denoted by the solid line and shaded region, respectively, evaluated over 29 single-shot measurements. In addition to changing the filament fluence profile, external focusing can also improve the pointing stability. Using a 10 m lens, we observed improvement in stability, relative to the non-focused case (Fig. 3). This improvement in PTP (RMS) stability from 642 μm (62.5 μm) to 310 μm (39 μm) was evaluated over 29 single-shot measurements. These spatial instabilities likely resulted from their formation around intensity ‘hot spots’ in the beam that fluctuated from shot to shot as well as turbulence experienced before the onset of filamentation [Chin 02]. Improved filament pointing stability was observed by Pfeifer, *et. al* using a circular phase mask [Pfei 06].

In addition to changing the filament fluence profile, external focusing can also improve the pointing stability. Using a 10 m lens, we observed improvement in stability, relative to the non-focused case (Fig. 4). This improvement in PTP (RMS) stability from 642 μm (62.5 μm) to 310 μm (39 μm) was evaluated over 29 single-shot measurements. These spatial instabilities likely resulted from their formation around intensity ‘hot spots’ in the beam that fluctuated from shot to shot as well as turbulence experienced before the onset of filamentation [Chin 02]. Improved filament pointing stability was observed by Pfeifer, *et. al* using a circular phase mask [Pfei 06].

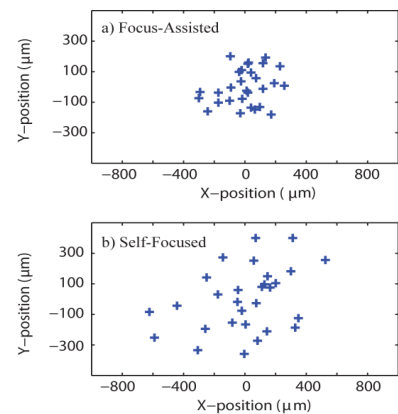

Fig. 4: Comparison of the pointing stability between non-focused and focused using a 10 m focal length lens.

This study has investigated the change in fluence profile of a laser filament with external focusing. We observed that external focusing increases the central fluence of the filament by a factor of 1.8 using a 10 m lens and a factor of 18 using a 1 m lens and in the case of 10 m lens focusing, an improved RMS pointing stability by a factor of 1.6. Therefore, lens focusing is advantageous for many laboratory filamentation experiments that require either higher central fluence and/or greater pointing stability; however, for applications of filamentation at distances ≥ 10 m, the irradiation

that are characteristic of lens focusing with $f \leq 10$ m commonly used in laboratory conditions are different from those expected at longer distances, or when no external focusing is used. Therefore results obtain by short focal length assisted filament because of laboratory constraints cannot be generalized directly to long distance applications.

2.3.0 Multiple filaments

Laser pulses with instantaneous powers many times that of the critical power for filamentation will form multiple filaments after optical collapse. The dynamics of the multiple filamentation process are susceptible to air turbulence and other effects that will produce local irradiance peaks from which the individual filaments form. Such dynamics result in random spatial distributions of filaments that vary on a shot-to-shot basis. For any application in which the arrangement of filaments are important, control of the multiple filamentation process is necessary.

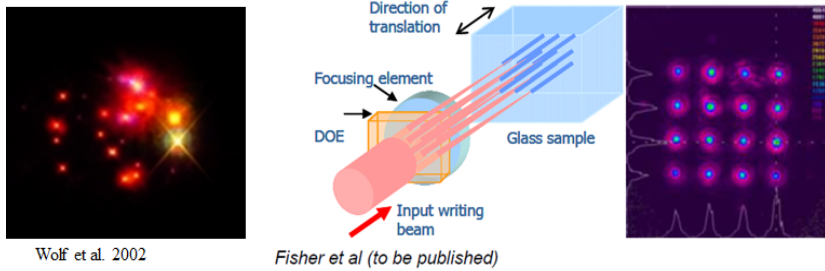

Fig. 5: Disorder (left) and ordered (right) arrays of filaments.

Multiple filamentation can be controlled through the use of laser pulses with two or more local irradiance peaks. Spatial profiles with multiple irradiance peaks can readily be obtained through the use of non-diffracting beams. Experiments conducted using helical beams, dual irradiance peak beams where the irradiance peaks rotate around the optical axis during propagation [Barb 11], have demonstrated the formation of helical filaments with the same approximate spatial dimensions of the helical beam used in their generation.

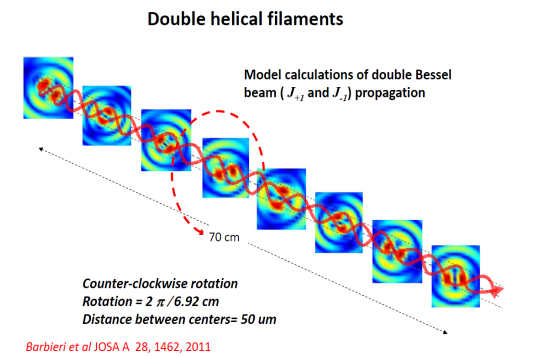

Fig. 6: Depiction of helical beams propagating through space.

Our results with helical filaments are consistent with similar results obtained

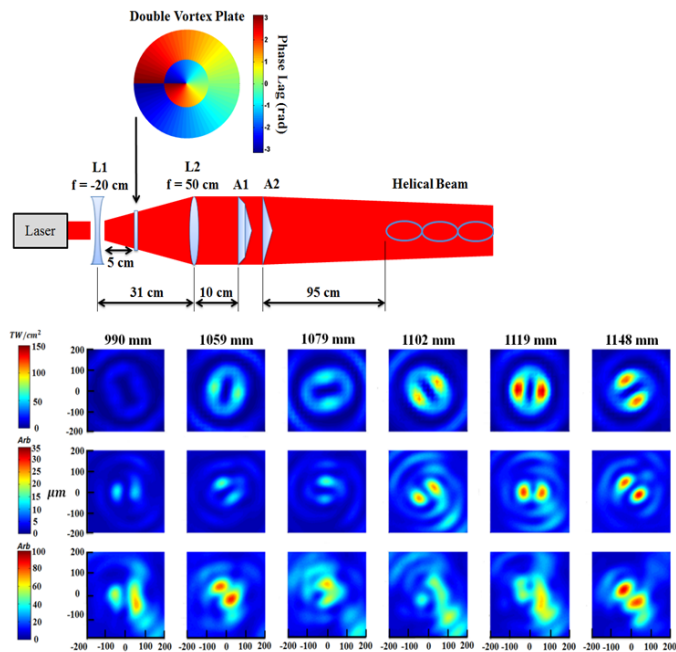

Fig. 7: Helical filament experiment. Top: Experimental setup. Bottom: Experimental results, including simulation of the setup (top row), 133 μ J helical beams (middle row), and 11.8 mJ helical filaments (bottom row).

using filamenting non-diffracting beams of other research groups, including the use of both Airy [Poly 09] and Bessel beams [Poly 08] to generate single and multiple filaments [Shiffler 11].

More recent efforts have been directed toward the generation of massive arrays of filaments. To control such filament structures, non-diffracting beams structures possessing

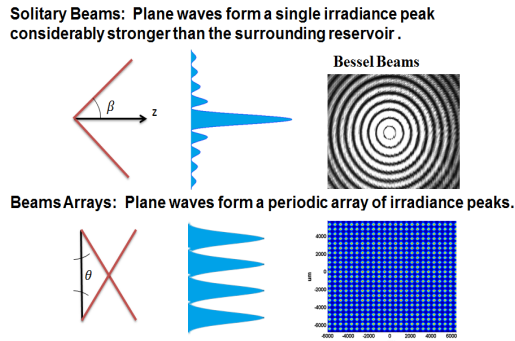

Fig.8: The relation between solitary non-diffracting beams and non-diffracting beam arrays.

arbitrarily large ordered spatial arrangements of local irradiance peaks have been devised (Fig.8). These non-diffracting beams are formed through the superposition of four plane waves, which can be generated from a single incident beam with an appropriately designed diffractive optical element. The layout and resulting non-diffracting beam as calculated from simulation is shown in Fig.9.

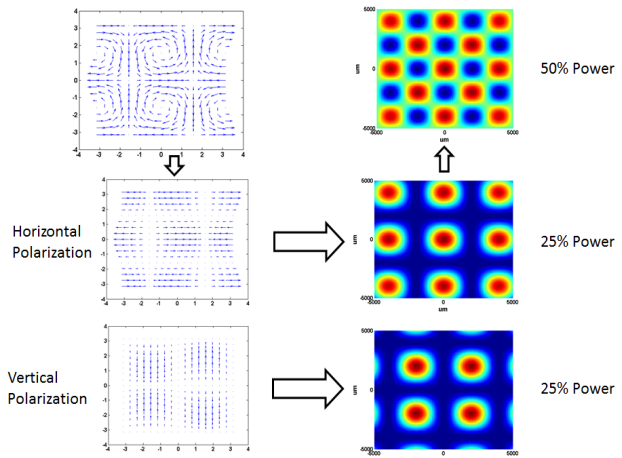

Fig.9: One of many grating arrangements that can be used to produce a non-diffracting beam array.



AFOSR/JTO MRI Annual Report 2016
Townes Laser Institute - College of Optics & Photonics –
University of Central Florida



3.0 PROGRAM ON INTERACTION WITH SOLIDS

3.2 RF emission studies

Laser filaments are readily able to ionize both air and solid matter, and the motion of the charge carriers liberated as a result produce RF radiation as low as 1 GHz in frequency. RF radiation resulting from the air plasma is particularly weak, having a conversion efficiency of only 10^{-8} [Sprangle 04]. However, matter irradiated using filaments produces far stronger RF emissions, which can be measured in the laboratory using RF electronics.

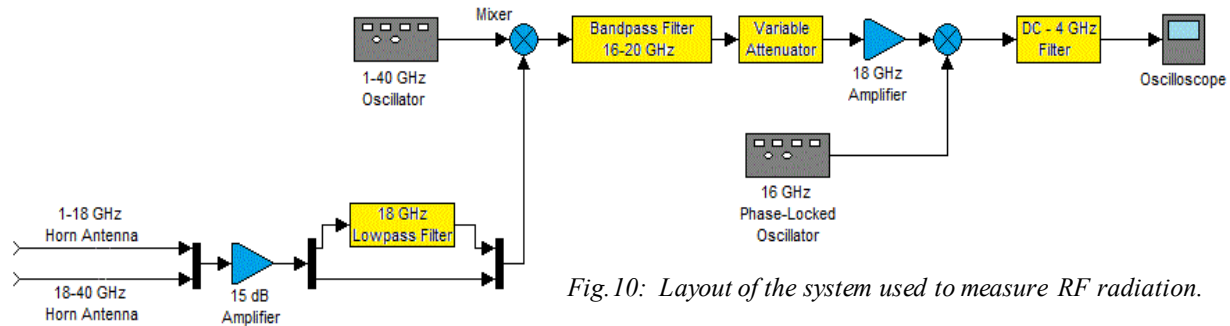

Fig.10: Layout of the system used to measure RF radiation.

RF radiation was measured using a 4 GHz bandwidth, 20 GS/s single-shot oscilloscope. A 4 GHz bandwidth heterodyning receiver was used to extend the range of the oscilloscope to 40 GHz. Radiation was coupled into the instrumentation using one of 2 broadband polarization sensitive horn antennas.



Fig. 11: Initial experimental setup.

Several experiments have been carried out in which a variety of materials have been irradiated with filaments. Initial experiments permitted a 8 mJ, 120 fs filamenting laser pulse to propagate 30 m down a utility chaseway before a 1 m focal length lens was used to focus laser pulse energy onto plate composed of either aluminum, copper, fused silica, plastic or sapphire, at normal incidence as depicted in **Error! Reference source not found.** Polarization resolved measurements of the resulting RF radiation were evaluated over a 1-18 GHz bandwidth using an antenna located 30 cm from the target. The resulting filament-matter interaction produced radiation which filled the bandwidth under investigation for all materials, as shown in Fig.12. For a second set of experiments, space, frequency and polarization resolved



AFOSR/JTO MRI Annual Report 2016

Townes Laser Institute - College of Optics & Photonics –

University of Central Florida



measurements of filament irradiated copper and aluminum were evaluated over a spectra range of 21 – 33 GHz. Filaments were generated by focusing 11.8 mJ, 50 fs pulses generated using MTFI with a 6 m concave mirror located 9 m from a metal target. Filamentation was observed to begin 3 m after the mirror and the laser pulse was permitted to travel 6 m in a filamenting state before striking the metal target at normal incidence. A quartz waveplate was used for laser polarization control, so the experiment could be carried out for both horizontal and vertical laser polarizations.

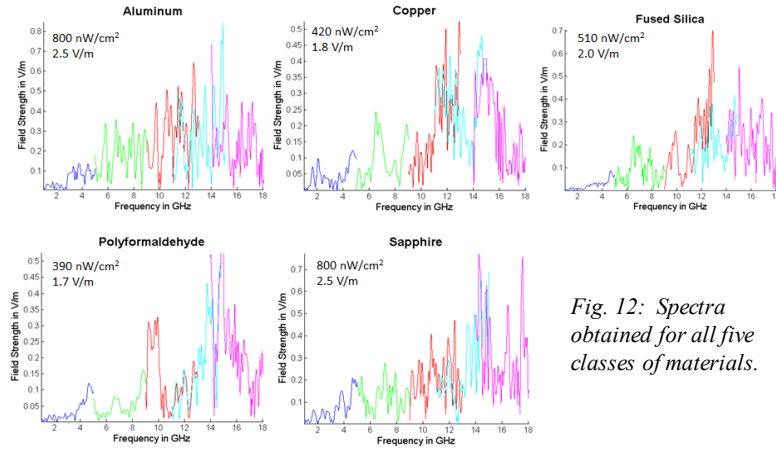

Fig. 12: Spectra obtained for all five classes of materials.

Antenna Polarization	$\theta = 20^\circ$	$\theta = 45^\circ$	$\theta = 90^\circ$	Above Target
Horizontal	91 W/m ²	144 W/m ²	185 W/m ²	222 W/m ²
Vertical	78 W/m ²	66 W/m ²	84 W/m ²	95 W/m ²
Difference	13 W/m ²	78 W/m ²	101 W/m ²	127 W/m ²
Sin ² Fit	13 W/m ²	56 W/m ²	110 W/m ²	110 W/m ²

Table 1: Summary of spatial resolved measurements of filament-matter induced RF radiation.

Measurements were taken using a horn antenna located 10 cm from the target, and various angles relative to the target surface normal. The results of the spatially resolved experiments were integrated over the spectrum evaluated using Parseval’s theorem and tabulated (Table 1). The table indicates the measured RF irradiance fits a $\sin^2 \theta$ radiation pattern, suggestion the filament-matter interaction acts as a dipole radiator.

A final set of experiments were carried out in the utility chaseway. Here filaments were generated by focusing 8 mJ, 50 fs pulses using lenses of either 20 cm, 50 cm, 1 m, 2 m, 3 m, or 5 m focal lengths. Planar targets of either copper or aluminum were placed within the focal plane, and polarization resolved spectra were obtained for 9-13 GHz by a horn antenna located 30 cm from the target. Integrated spectral power was evaluated as a function of focal length.



AFOSR/JTO MRI Annual Report 2016
Townes Laser Institute - College of Optics & Photonics –
University of Central Florida

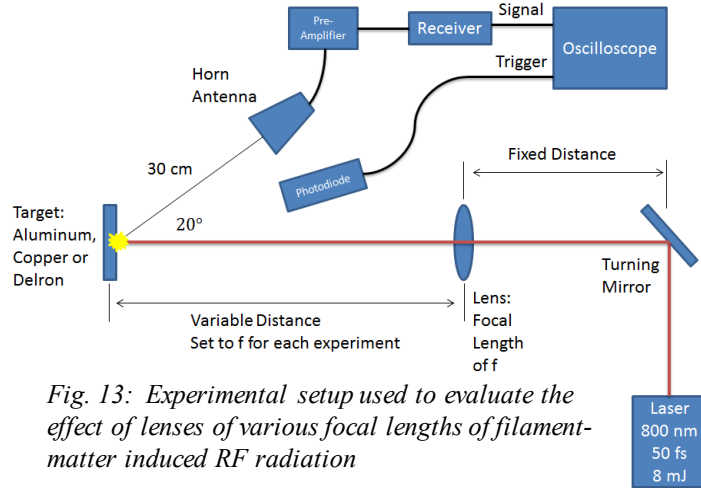

Fig. 13: Experimental setup used to evaluate the effect of lenses of various focal lengths of filament-matter induced RF radiation

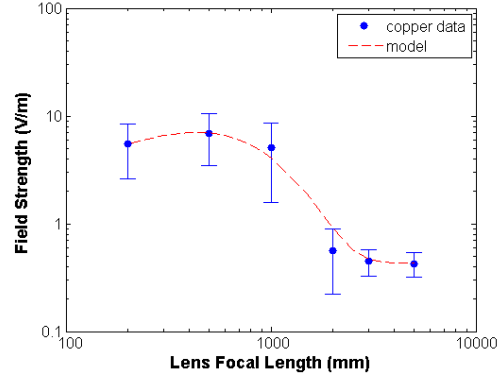

Fig. 14: Effect of preparing a filament with lenses of different focal lengths on the resulting filament-matter RF radiation.

The relation between the laser plasma generated RF emission and lens focal length is shown in Fig.14 for copper. Two regimes are visible: a large field strength (~ 5 V/m in average) is observed for focal lengths of less than a meter while a lower signal strength (0.5 V/m) for focal lengths exceeding one meter. Both regimes can be described by a simple model, which attributes the observed RF radiation to a dipole formed from electrons the boil away from the surface on a femtosecond time scale, as simulated through the use of a Boltzmann distribution. Self-focusing in the large focal length limit prevents measured field strengths from going below 0.4 V/m, while the finite availability of electrons in copper prevents measured field strengths from exceeding 10 V/m.



AFOSR/JTO MRI Annual Report 2016
Townes Laser Institute - College of Optics & Photonics –
University of Central Florida



4.0 FINAL TWO YEARS OF THE PROGRAM.

During the final two years we began to curtail our investigations of molecular alignment relative to filamentation. The first four years of the investigation has yielded on the process itself, and has explained qualitatively many of the fluorescence features we see. Moreover, the analytical theoretical investigation at Northwestern University by Tamar Seiderman and her group added support to our fundamental understanding of the phenomena. That being said, we encountered severe computational roadblocks when we attempted to make a comprehensive computation model of molecular rotation relevant to filamentation. Moreover, as we reviewed the many issues in front of us that had more significance, both for the development of filamentation science and technology, and possible applications of filamentation, we could not justify a continuing effort on molecular rotation studies. This option was always in the planned program when we embarked on this contract, in that, in the beginning we were not sure of the significance it would have, and therefore left open the option of putting resources elsewhere.

4.1 Enhanced Research Program

At the end of Year 3, we presented to the HEL JTO an enhanced research program (with out any increase in funds) which would take advantage of the DURIP funds we have received from AFOSR, but also those from ARO, and the equipment funds allocated within the ARO MURI program on Fundamental Filamentation Science that is continuing to run. Anchored by a large \$700k DURIP from ARO, we proposed the design, assembly and testing of a mobile high power femtosecond propagation facility, MU-HEL. These funds, together with some from this MRI program (~ \$100k) authorized by the HEL JTO office are now vested in this new mobile facility. A diagram of this facility is shown below.

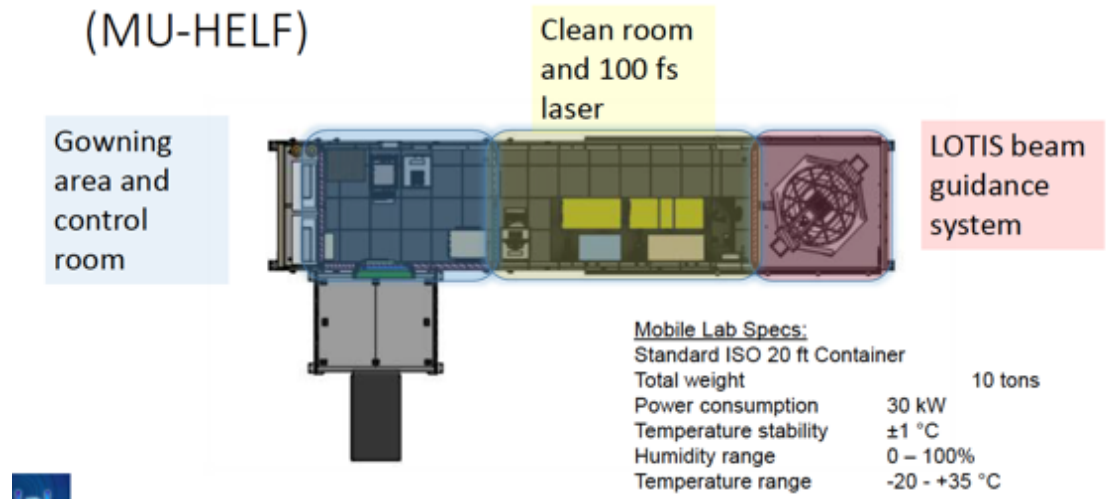

It is designed into a 40' Conex container, with a cleanroom for the ultrafast laser and a special fixture for a full automated projection system (LOTIS). The laser system was purchase in parts, and tested during the last two years in the LPL laboratories at UCF. Specifications for the laser are that it replicate the performance of the MTFI system in LPL, that is 500 mJ, 40 fs, 10 Hz,



AFOSR/JTO MRI Annual Report 2016
Townes Laser Institute - College of Optics & Photonics –
University of Central Florida



with very uniform output phase front control to allow advanced forms of filament engineering to be investigated. The MU-HELFS laser will have a longer pulse duration, stemming from the ultrafast fiber laser front end incorporated for greater stability. At the present time all the principal components have been delivered. The container arrived at the beginning of January, 2017, and we are in the process of activating it, and the laser components, at the TISTEF laser range on Merritt Island. Some photos of the facility are shown below.



Here shown is the projector end of the MU-HELFS, and to the left a mobile power generation and cooling unit. The facility, when operational will be linked to a fast tracking unit (funded through a DURIP from ONR). It will also facilitate HELFS laser systems up to the 10 kW level.



This new facility should be operational by the end of the summer 2017, introducing a new phase into ultrafast laser propagation.



AFOSR/JTO MRI Annual Report 2016
Townes Laser Institute - College of Optics & Photonics –
University of Central Florida



4.1.1 Robustness of the filament along atmospheric propagation

(some of the text for this report is drawn from detailed MS and Ph.D theses referred to in the text. Copies of these thesis will be supplied with the Final Report)

4.1.2 Single filament propagation through aerosol clouds.

The work reported the final year on this topic refers principally to studies that examine the propagation of filaments through clouds. With the support of a DURIP from AFOSR, we have designed, constructed, assembled and tested a 5 m long cloud chamber capable of creating clouds of aerosol of given diameter and density, with control over temperature and background pressure. Here we first describe the new equipment we have assembled and then the results we have so far recorded.

4.1.3 Chamber for laser propagation through Aerosol Media (CLaPTAM)

As filaments propagate, they encounter pressure and temperature changes due to the change in altitudes or different landscapes. **Error! Reference source not found.** (a) shows the temperature and pressure of earth’s atmosphere for altitudes from 0 to 120 km above sea-level. The clouds are spread throughout the earth atmosphere; however, most are present up to 5.5 km above sea level. The temperature and the pressure at this altitude are -20°C and 0.5 atm respectively. To simulate the propagation of laser filament in such conditions (from ground to ~ 5.5 km above sea level), the Chamber for Laser Propagation Through Aerosol Medium (CLaPTAM) was built.

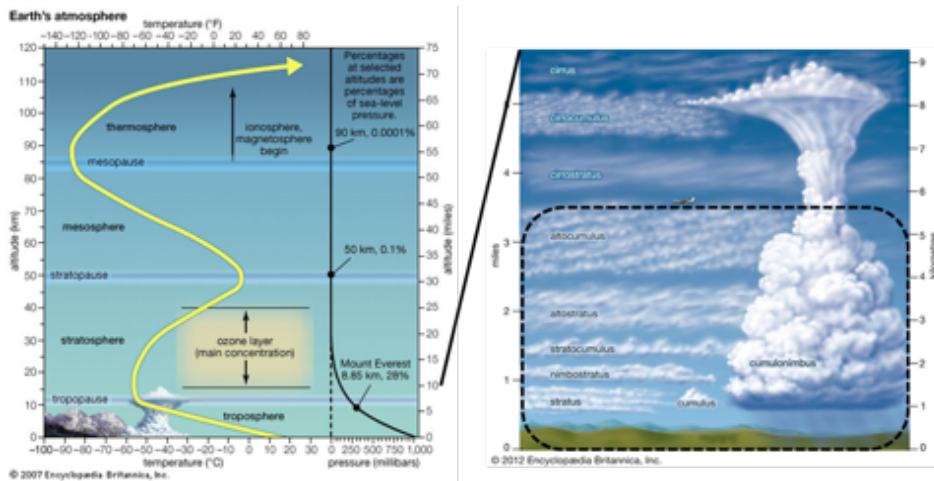

Fig 15: Earth's atmosphere (source: Encyclopediab Britannica, Inc.)

The customized chamber (built by A&N Corporation) is composed of three identical segments that can be used alone as 70 inches (1.78 m) of propagation or they can be joined together to give a maximum propagation length of 210 inches (5.33 m). The outer diameter of the chamber is 20



AFOSR/JTO MRI Annual Report 2016
Townes Laser Institute - College of Optics & Photonics –
University of Central Florida



inches (50 cm) as shown in Fig 15. Each of the individual chambers has total of 10 viewing windows (5 windows on each side) with 4

inches (100 cm) of clear aperture. The chamber also has 10 ports (QF 40-150-SF) per individual segments for connection purposes. The 10 ports are used for, but not limited to: [1] Pump connection, [2] Condensing unit inlet/outlet, [3] Aerosol generator, [4]

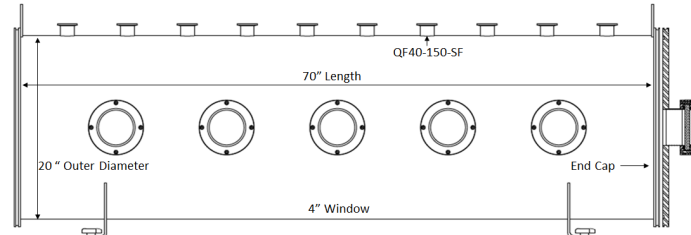

Fig. 15: Schematic of one segment of CLaPTAM

Thermometer, [5] Pressure Gauge, [6] Humidity sensor, [7] Fan, [8] Power, [9] Cleaning/drying pipeline, [10] USB/trigger cable. Each of the individual chambers has its own condensing unit to regulate the temperature. These customized condensing units (Scientemp Corporation) use R404A as the refrigerant and is able to cool each 12 ft³ (0.32 m³) chamber to -20 °C. The compressed refrigerant from the pump is directed into the chamber through one of the QF 40-150-SF ports to the evaporator where the heat exchange from the chamber to the refrigerant takes place.

The warm refrigerant then is directed out of the chamber using the same port to the heat sink that is cooled by fanned air. This circulation continues until the temperature inside the chamber has reached the desired value. Three fans are positioned inside the chamber to help homogenizing temperature in the chamber.

Error! Reference source not found. shows the change in the temperature of the CLaPTAM as the condensing units are on. It takes about 3 hours to cool down from room temperature of 21 °C to 0 °C about 10 hours for the chamber to be cooled down to -10 °C.

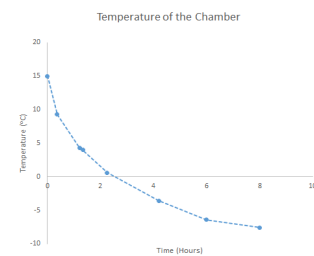

Fig. 16: change in temperature of CLaPTAM with respect to time.

A cloud is composed of multiple aerosols with its size varying from 1µm to 120 µm (Hsieh, 2007; Kapoor, et al., 1946). To mimic condensed aerosol media in the atmosphere such as fogs and clouds, CLaPTAM is equipped with a multiple aerosol generator. The multiple aerosol generator (Koolfog) produces 20 µm diameter droplets at a rate of 0.5 gallon per minute. In order to fill the chamber uniformly along the propagation axis, the main outlet of the multiple aerosol generator was divided into 6 evenly spaced outlets along the chamber. The fans mentioned previously distribute the aerosols uniformly along the entire length of the chamber.



AFOSR/JTO MRI Annual Report 2016
Townes Laser Institute - College of Optics & Photonics –
University of Central Florida



The grazing incidence filament beam profiler shown in **Error! Reference source not found.**

was developed in the Laser & Plasma Laboratory by Khan Lim¹. In order to save the optics from damaging due to the high intensity of the filament, the first 2" wedges have an angle of incidence (AOI) set to $\sim 83^\circ$ to distribute the filament profile over a large area (8.2 time greater than initial area of the beam). The reflected beam (36 % for P-polarized light) from the first wedge was then sent to a second 2" wedge also set to $\sim 83^\circ$. The reflected beam from the second wedge then goes through the next two 1" wedges at 65° of incidence angle that are $\sim 1\%$ reflective. The beam was then sent to a fifth wedge at 45° ($\sim 1\%$ reflectivity) through a 100 mm focusing lens to provide a 1:1 image of the filament profile onto a CCD camera (The Imaging Source DMK72BUC02).

Neutral density filters were used to prevent the saturation of the CCD camera. The grazing incidence filament beam profiler was fixed on a moving rail to measure the filament profile along its propagation inside the chamber (Fig.17). A particle size analyzer (Malvern Spraytec) was installed to understand the propagating medium as well as to analyze the effect of the laser filament on the propagating aerosol medium after the interaction. The particle size analyzer uses

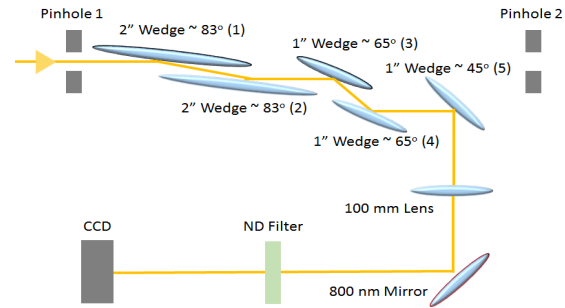
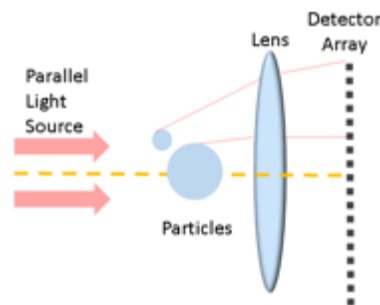

Fig.16: schematics of multiple wedge grazing incidence filament beam profiler.



Fig.17: Grazing incidence filament beam profiler on the rail inside CLAPTAM



laser diffraction to measure the size distribution of multiple aerosols from the scattered light. The particle size analyzer unit contains a transmitter module and receiver module. The transmitter module is a He-Ne laser with its maximum output power of 4 mW while the receiver module is a 36 element log-spaced array. The He-Ne laser beam is scattered as it passes through the analyzed particles as illustrated in Fig 18. The scattering angle of the beam is

¹ K. Lim and M. Richardson, "Laser filamentation-beyond self-focusing and plasma defocusing," PhD Dissertation, CREOL, The College of Optics and Photonics, Orlando, 2014.



AFOSR/JTO MRI Annual Report 2016
Townes Laser Institute - College of Optics & Photonics –
University of Central Florida



relatively larger for smaller particles than for the larger particles. The receiver module analyzes the scattering pattern to provide the size distribution of the particles.

Fig.18: Basic principal of laser diffraction particle size analyzers.

Unlike the other particle size analyzers, the sample location of the particle size analyzer is in open air where the filament interaction with aerosols could take place. This allows a measurement of the propagation medium before and after the interaction with a laser filament.

4.1.4 Droplet Explosions

Intense vaporization of the water particles from laser-droplet interaction leads to a droplet explosion. Depending on the initial parameters of the laser and the droplet size, the time scale for the formation of the fragments varies. As it can be seen in Fig.19, the 56 μm droplet fragments into nano-sized particles in a time scale of 5 μs .

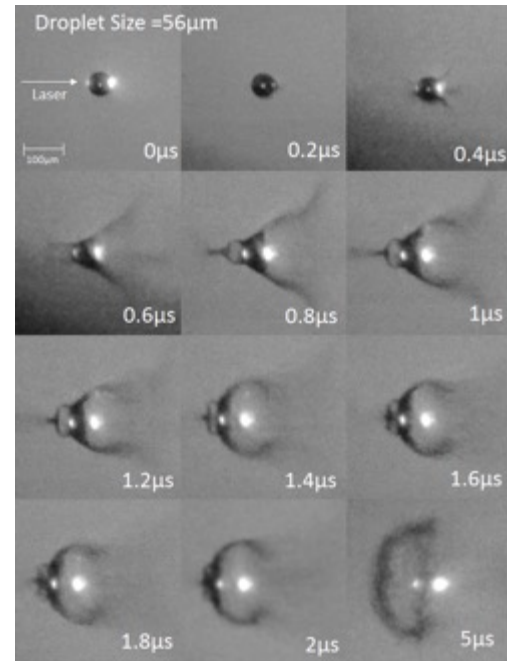
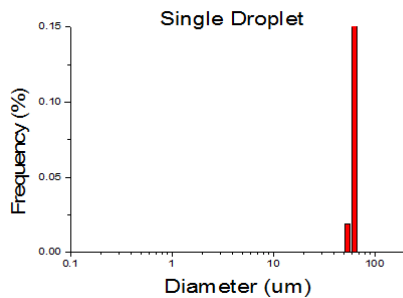

Fig 19: shadowgraph images taken at different times of a 56 μm droplet located at 15 mm prior to the focusing plane, interacting with 100 fs laser pulses focused with a 250 mm focal length lens with input energy of 0.78 mj.

4.1.5 Particle size distribution.



AFOSR/JTO MRI Annual Report 2016
Townes Laser Institute - College of Optics & Photonics –
University of Central Florida



A filament can be used to induce water condensation. Filament induced water condensation experiments showed a growth of the droplet sizes and a large increase in nano-sized aerosols^{2,3} However, the fundamentals of the filament assisted water condensation is not fully understood yet. An experiment was conducted to understand the increase in the nano-sized aerosols. A stream of single droplets (with a nominal diameter of 63 μm) was positioned within the measuring field of view of the particle size analyzer. The particle distribution was centered at 60 μm with a variance of 2 μm as shown in **Error! Reference source not found.**

Fig.20: particle size distribution of droplets before the filament-droplet interaction.

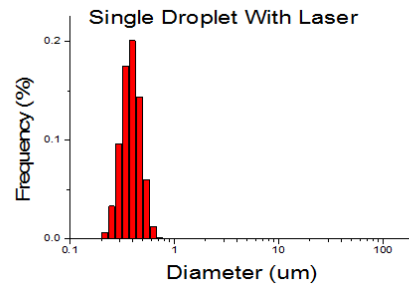

The measured particle size distribution shows that the droplet dispenser is generating a quasi-monodisperse train of droplets. When the filament interacts with the droplets, this distribution is modified. An ultrafast laser pulse with 5 mJ, 50 fs pulses at 800 nm was focused with 1.2 m focusing optics to induce a single filament. The filament-droplet interaction fragments the droplet into smaller aerosols with a size distribution centered at 400 nm with a variance of 100 nm.

Fig.21: particle size distribution of droplets after the filament-droplet interaction.

² P. K. J. Rohwetter, K. Stelmaszczyk, Z. Hao, S. Henin, N. Lascoux, W. Nakaema, Y. Petit, M. Quisser, R. Salame, E. Salmon, L. Woste and J. Wolf, "Laser-induced water condensation in air," *Nature Photonics*, vol. v, p. 451, 2010.

³ Pohl, F. Schneider, J. Kasparian, K. Weber, L. Woste and J. Wolf, "Field measurements suggest the mechanism of laser-assisted water condensation," *Nature Communications*, vol. 2, p. 456, 2011.



AFOSR/JTO MRI Annual Report 2016
Townes Laser Institute - College of Optics & Photonics –
University of Central Florida



A study by Henin *et al.* showed the particle generation of different sizes as the filament interacted with humid air⁴. They have observed three different size ranges that behave differently as they interact with the laser. For the nanoparticles with 25 nm median diameter, the concentration increases as relative and absolute humidity increases and decreases as the temperature increases. For the particles in the 230-400 nm range the concentration increases with an increase in relative humidity but the concentration decreases as temperature and absolute humidity increases. For the particle with its diameter around 500 nm, the concentration of the particles are no longer dependent on the temperature, relative and absolute humidity. The observation of the nanoparticles from a single filament interaction with a single droplet is undoubtable. However further studies are required to understand the changes in the size distribution of the nanoparticles due to the surrounding environment for a single filament interaction with a single droplet.

Fig. 22: particle size distribution of droplets (a) before and (b) after the filament interaction with multiple aerosols.

Another experiment was conducted to understand the impact of the filament on concentrated aerosols such as clouds and fogs, the distribution of the particles generated from a large collection of particles interacting with a filament was measured (**Error! Reference source not found.**). Multiple aerosols with a large peak distribution at 5.64 μm and a variance of 3.05 μm interacted with a single filament. As for the case of a single droplet, sub-micro sized aerosols are created (**Error! Reference source not found.** b). Comparing the distribution of the droplets before and after interacting with the filament (**Error! Reference source not found.**) indicates a shift in the original distribution from 5.65 μm to 6.43 μm .

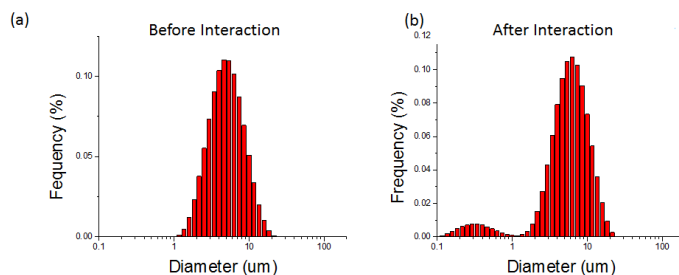

This increased particle size could be explained by the coalescence of the generated aerosols with the aerosols that did not interact with the filament. Several studies focusing on the growth of the particle sizes showed that the photochemical processes from laser-aerosol

⁴ S. Henin, Y. Petit, P. Rohwetter, K. Stelmazczyk, Z. Hao, W. Nakaema, A. Volgel, T. Pohl, F. Schneider, J. Kasparian, K. Weber, L. Woste and J. Wolf, "Field measurements suggest the mechanism of laser-assisted water condensation," *Nature Communications*, vol. 2, p. 456, 2011.



AFOSR/JTO MRI Annual Report 2016
Townes Laser Institute - College of Optics & Photonics –
University of Central Florida



interaction were important to consider. The laser filament produces O_3 and NO_2 molecules from the ionization of air, which leads to the formation of HNO_3 and then H_2O - HNO_3 nucleation^{5,6}. Further experiments should be conducted to understand the interplay between the fragmentations of the droplets along with the photochemical processes on the growth of the droplets to optimize the laser-induced water condensation in air. In addition to this, the correlation between the growth of the droplet and environmental condition (temperature, pressure, and humidity) should be studied. Nonetheless, the fundamental study of a single aerosol interaction with a single laser filament mentioned in this chapter is a step towards the complete understanding of filament interaction with multiple aerosols such as clouds and fogs.

4.1.6 Effect of pressure on filament propagation

Aerosols are not the only variable that has an impact on filament propagation in atmosphere. Pressure changes due to the altitude also affect the atmospheric propagation of filaments. In this chapter, the pressure dependence of filament characteristics such as its propagation, intensity profile and supercontinuum generation are discussed.

4.1.7 Previous studies

Several studies have been done on filament propagation in adverse conditions such as highly turbulent air^{7,8}, reduced pressures and natural rain in “atmospheric scale” ranges⁹.

⁵ P. K. J. Rohwetter, K. Stelmasczyk, Z. Hao, S. Henin, N. Lascoux, W. Nakaema, Y. Petit, M. Quisser, R. Salame, E. Salmon, L. Woste and J. Wolf, "Laser-induced water condensation in air," *Nature Photonics*, vol. v, p. 451, 2010.

⁶ . Henin, Y. Petit, P. Rohwetter, K. Stelmasczyk, Z. Hao, W. Nakaema, A. Volgel, T. Pohl, F. Schneider, J. Kasparian, K. Weber, L. Woste and J. Wolf, "Field measurements suggest the mechanism of laser-assisted water condensation," *Nature Communications*, vol. 2, p. 456, 2011.

⁷ R. Salamé, N. Lascoux, E. Salmon, R. Ackermann and J. Kasparian, "Propagation of laser filaments through an extended turbulent region," *Applied Physics Letters*, vol. 91, no. 17, p. 171106, 2007.

⁸ R. Ackermann, G. Méjean, J. Kasparian, J. Yu, E. Salmon and J.-P. Wolf, "Laser filaments generated and transmitted in highly turbulent air," *Optics Letters*, vol. 31, no. 1, pp. 86-88, 2006.

⁹ . Mechain, G. Mejean, R. Ackermann, P. Rohwetter, Y. Andre, J. Kasparian, B. Prade, K. Stelmasczyk, J. Yu, E. Salmon, W. Winn, L. Schlie, A. Mysyrowicz, R. Sauerbrey, L. Woste and J. Wolf, "Propagation of fs TW laser filaments in adverse atmospheric conditions," *Appl. Phys. B*, vol. 80, pp. 785-789, 2005.



AFOSR/JTO MRI Annual Report 2016
Townes Laser Institute - College of Optics & Photonics –
University of Central Florida



Multiphoton ionization¹⁰ and blue-shift¹¹, effects caused by plasma from femtosecond pulses have been studied in low pressure conditions, also called ‘collision-less’ regime ($p \ll 1 \text{ atm}$). Supercontinuum generation and self-focusing have been investigated experimentally, in the high-pressure regime ($p > 1 \text{ atm}$)^{12, 13} and they observed that the threshold for supercontinuum generation and self-focusing decreases as the pressure increases. The pressure independence of some characteristics of filaments such as the clamping of its intensity and its amplitude at the self-focusing distance have been shown¹⁴.

The dependence of start location of the filament on pressure has been studied experimentally and numerically^{15,16}. However, the intensity spatial profile of the filament along propagation has never been the focus of these studies. Most of the energy of the filament that interacts with the droplet is lost during the filament-droplet interaction. Therefore, by knowing the initial profile of the filament before the interaction, it is possible to estimate the energy loss of the filament during the filament-aerosol interaction. The change in beam profile of the filament with pressure, therefore, needs to be understood to minimize or to account for the energy loss during the interaction.

4.1.8 Length, beam profile and spectrum of a filament at different pressures.

¹⁰ A. l'Huillier, L. Lompre, G. Mainfray and C. Manus, "Multiply charged ions induced by multiphoton absorption in rare gases at 0.53 μm ," *Physical Review A*, vol. 27, no. 5, p. 2503, 1983.

¹¹ W. Wood, G. Focht and M. Downer, "Tight focusing and blue shifting of millijoule femtosecond pulses from a conical axicon amplifier," *Optics Letters*, vol. 13, no. 11, p. 984, 1988.

¹² P. Corkum, C. Rolland and T. Srinivasan-Rao, "Supercontinuum Generation in Gases," *Physical Review Letters*, vol. 57, no. 18, pp. 2268-2271, 1986.

¹³ M. Mlejnek, E. Wright and J. Moloney, "Femtosecond pulse propagation in argon: A pressure dependence study," *Physical Review E*, vol. 58, no. 4, p. 4903, 1998.

¹⁴ J. Bernhardt, W. Liu, S. Chin and R. Sauerbrey, "Pressure independence of intensity clamping during filamentation: theory and experiment," *Applied Physics B*, vol. 91, pp. 45-48, 2008

¹⁵ A. Couairon, M. Franco, G. Mechain, T. Olivier, B. Prade and A. Mysyrowicz, "Femtosecond filamentation in air at low pressures: Part I: Theory and numerical simulations," *Optics Communications*, vol. 259, pp. 265-273, 2006.

¹⁶ G. Mechain, T. Olivier, M. Franco, A. Couairon, B. Prade and A. Mysyrowicz, "Femtosecond filamentation in air at low pressures. Part II: Laboratory experiments," *Optics Communications*, vol. 261, pp. 322-326, 2006.



AFOSR/JTO MRI Annual Report 2016
Townes Laser Institute - College of Optics & Photonics –
University of Central Florida



To investigate the effect of pressure on the characteristics of the filament propagating in different atmospheric conditions, two different experiments were conducted with CLaPTAM to measure the length and the beam profile of the filament at different pressures.

The output of the MTFL laser with 5 mJ, 50 fs pulses at 800 nm and 10 Hz repetition rate was sent to the CLaPTAM where the pressure was controlled from 76 torr to 760 torr. The total distance between the output of MTFL and CLaPTAM was 11 m. The entire pathway of the laser was closed with 4 inch PVC pipe to minimize any turbulences as well as for safety reasons. A 1.2 m focusing lens was placed just prior to the entrance window of CLaPTAM to induce filament. The filament pointing stability was measured out to be $\pm 200 \mu\text{m}$.

The plasma emission was collected from the side using a standard digital SLR camera (Cannon 70D) with 30 second exposure time (i.e. accumulation of 300 single filament images), to measure the filament length. The grazing incidence beam profiler was used to monitor the spatial profile as the filament propagates in air at different pressures.

Images from the nitrogen emission of the filament created with a 1.2 m assisted focusing are shown in **Error! Reference source not found.** (a). As the pressure decreases from 760 torr to 76 torr, the collapse point moves further away from the lens, shortening the filament. This observation can be explained using Marburger's equation

$$Z_c = \frac{0.184w_0^2k_0}{\sqrt{\left(\left(\frac{P}{P_{cr}}\right)^{\frac{1}{2}} - 0.853\right)^2 - 0.0219}}$$

Decreasing the pressure reduces the nonlinear index of refraction. This induces an increase of the critical power and as a consequence of the self- focusing distance.

The start and the end locations of the filament are determined by measuring the spatial extent of the plasma emission. A shift of 50 mm in filament start location and a shift of 5 mm in the end location were observed when the pressure was decreased from 760 to 76 torr. Higher peak intensity was visible for the lower pressure. At lower pressures, nonlinear effect is

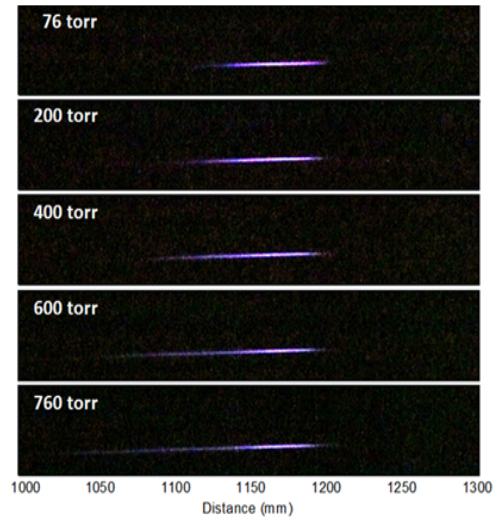

Fig. 23 (a) side images of the plasma emission from the filament as the pressure varied from 76 torr to 760 torr for 1.2 m focusing condition.



AFOSR/JTO MRI Annual Report 2016
Townes Laser Institute - College of Optics & Photonics –
University of Central Florida



weakened and therefore the beam follows Gaussian propagation resulting in a beam waist of $\sim 85 \mu\text{m}$ at the focus. For Gaussian propagation, the entire beam energy is within the focused beam. However, the filament has a clamped intensity and its energy is distributed between the core of the filament and the energy reservoir. Therefore, the beam has higher intensity at lower pressures for 1.2 m focusing condition, resulting in brighter plasma emission.

Numerical simulations of the one-dimensional NLSE algorithm¹⁷ were also performed for various pressures. The initial parameters of the simulation were set to be a Gaussian pulse with 1.67 mJ, 50 fs, 800 nm, 5 mm in diameter (FWHM) with a 1.2 m focusing lens, to match the experimental conditions. a reduction factor of 3 was necessary in the NLSE code¹⁷. The diameter of the filament (FWHM) along propagation through different pressures was calculated (Fig

Fig 24: numerical calculation of (a) the diameter, (b) the plasma density of the filament induced by 1.2 m external focusing in different pressures using nlse. (c) experimental data of the intensity distribution of the plasma emission from the filament as the pressure varied from 76 torr to 760 torr for 1.2 m focusing condition.

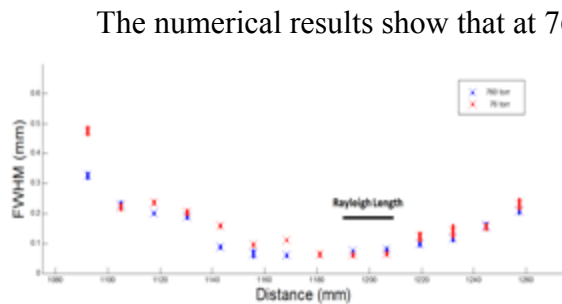

The numerical results show that at 760 torr, the FWHM of the beam follows a linear trend until ~ 1100 mm from the focusing lens (Fig 12). The deviation from the linear can be identified as the start of the filament, the collapse location. As the pressure decreases, the collapse location is correctly moving away from the lens as discussed above and observed experimentally. For a pressure of 76 torr, the beam collapse location was ~ 1150 mm. A shift of 50 mm in filament start location was observed as the pressure decreased from 760 to 76 torr which is in agreement with the experimental data (Fig.24). The plasma density calculation also agrees with the experimental data of the intensity distribution of the plasma emission. The maximum plasma density and maximum intensity from plasma emission occur at 76 torr.

Fig.25: experimental data of the filament diameter at two extreme pressures [76 (red) and 760 (blue) torr] for 1.2 m external focusing.

The beam profile of the filament was measured along propagation at different pressures using the grazing incidence filament beam profiler. As it can be seen in Fig 25, the beam profile is stable from 1150 mm \sim 1210 mm for the 760 torr case while it is only stable from 1180 mm \sim

¹⁷ K. Lim, M. Durand, M. Baudalet and M. Richardson, "Transition from linear-to nonlinear-focusing regime in filamentation," *Scientific Reports*, vol. 4, p. 7217, 2014.



AFOSR/JTO MRI Annual Report 2016
Townes Laser Institute - College of Optics & Photonics –
University of Central Florida



1210 mm for 76 torr case. However, there is not much of a difference in the filament profile measurements for the two different pressures.

Detailed studies of the filament and post-filament spectrum were also made during the final year of the program, and these are summarized, together with the results of detailed numerical calculations in the 5th year annual report.

4.2.0 Interaction of filaments with solid targets at intermediate ranges.

In previous reports we failed to describe in detail the technology and methodology we use to characterize the RF emission generated at a distance by a single filament. This was rectified in the 5th and final year report. Much of this has not yet been published.

The remote generation of radiation represents a new paradigm for the delivery of electromagnetic radiation. In contrast to conventional means of delivering radiant energy, where energy is required to propagate over extended distances before use, remote generation uses a laser driven transient source of radiation, typically a plasma, to generate radiant energy in the precise point in space where it is required. Such remote sources of radiation have a range of applications, including the generation of remote white light sources of radiation for remote spectroscopy and the generation of remote radio frequency sources for use in remote sensing and ground penetrating radar^{18,19}. Due to the nature of the laser plasma typically used, such remote radiation sources are often suitable for the generation of electromagnetic radiation ranging in frequency from the RF spectrum to the ultraviolet spectrum^{20,21}. In the work presented here, investigation of such remote sources will be confined to the radio frequency spectrum.

The creation of a remote RF radiation source requires a means to generate and drive the transient radiation source. An ideal means of driven the source is to employ laser filaments which enabled the delivery of confined ultrafast pulses over extended distances. Because of the presence of

¹⁸ H. Nakajima, Y. Shimada, T. Somekawa, M. Fujita and K. A. Tanaka, "Nondestructive Sensor Using Microwaves from a Laser Plasma," *Plasma and Fusion Research: Letters*, vol. 4, p. 003, 2009.

¹⁹ H. Nakajima, Y. Shimada, T. Somekawa, M. Fujita and K. A. Tanaka, "Nondestructive Sensor Using Microwaves from Laser Plasma by Subnanosecond Laser Pulses," *IEEE Geoscience and Remote Sensing Letters*, vol. 6, no. 4, pp. 718-722, 2009.

²⁰ J. S. Pearlman and G. H. Dahlbacka, "Emission of rf radiation from laser-produced plasmas," *Journal of Applied Physics*, vol. 49, no. 1, pp. 457-459, 1978.

²¹ H. Hamster, A. Sullivan, S. Gordon, W. White and R. W. Falcone, "Subpicosecond Electromagnetic Pulses from Intense Laser-Plasma Interaction," *Physical Review Letters*, vol. 71, no. 17, pp. 2725-2728, 1993.



AFOSR/JTO MRI Annual Report 2016
Townes Laser Institute - College of Optics & Photonics –
University of Central Florida



transient currents driven by the ponderomotive force and other effects within the plasma found in the filament core, the laser filament provides a source of remotely generated RF radiation as it propagates through the atmosphere^{22,23}. However, the laser filaments prove to be highly inefficient sources of RF radiation, having conversion efficiencies on the order of 10^{-9} , (ref.²⁴) unless additional methods are employed to enhance the resulting RF radiation²⁵. If considerable RF power is required from the laser filament, a means other than the filamentation process in air is required to extract radio frequency radiation from laser filaments.

Alternatively, filaments can be used to irradiate solid matter. The irradiation of solid matter with ultrafast pulses has been shown to generate RF radiation both in vacuum^{26,27} and in air¹¹¹. When matter is irradiated with low irradiance pulses, the irradiated surface will undergo melting and vaporization consistent with conventional heating. However, for femtosecond pulses with field strengths in excess of 10^8 V/cm, dielectric breakdown is expected²⁸ based on extrapolation from 10 ps dielectric breakdown experiments. For filaments possessing an irradiance $10^{13} - 10^{14}$ W/cm², the associated electric field is $(0.9 - 2.7) \cdot 10^8$ V/m, which falls along the predicted threshold of dielectric breakdown. Any successful effort to increase the on-axis irradiance beyond that obtained for an unaugmented filament will yield an irradiance in excess of the breakdown threshold. Should the breakdown threshold be exceeded, the high irradiance present in the core of the filament will convert the material surface directly from a solid to a plasma on a sub-picosecond timescale²⁹. The plasma and electron density resulting from this process is far in

²² C.-C. Cheng, E. M. Wright and J. V. Moloney, "Generation of Electromagnetic Pulses from Plasma Channels Induced by Femtosecond Light Strings," *Physical Review Letters*, vol. 87, no. 21, p. 213001, 2001.

²³ S. Tzortzakis, G. Mechain, G. Patalano, Y.-B. Andre, P. B., M. Franco and Mysyrowicz, "Coherent subterahertz radiation from femtosecond infrared filaments in air," *Optics Letters*, vol. 27, no. 21, pp. 1944-1946, 2002.

²⁴ P. Sprangle, J. R. Penano, B. Hafizi and C. A. Kapetanacos, "Ultrashort laser pulses and electromagnetic pulse generation in air and on dielectric surfaces," *Physical Review E*, vol. 69, p. 066415, 2004.

²⁵ P. Sprangle, J. R. Penano, B. Hafizi and C. A. Kapetanacos, "Ultrashort laser pulses and electromagnetic pulse generation in air and on dielectric surfaces," *Physical Review E*, vol. 69, p. 066415, 2004.

²⁶ F. S. Felber, "Dipole radio-frequency power from laser plasmas with no dipole moment," *Applied Physics Letters*, vol. 86, p. 231501, 2005.

²⁷ Z.-Y. Chen, J.-F. Li, J. Li and Q.-X. Peng, "Microwave radiation mechanisms in a pulse-laser irradiated Cu foil target revisited," *Physica Scripta*, vol. 83, p. 055503, 2011.

²⁸ D. von der Linde and H. Schuler, "Breakdown threshold and plasma formation in femtosecond laser-solid interaction," *Journal of the Optical Society of America B*, vol. 13, no. 1, pp. 216-222, 1996.

²⁹ D. von der Linde, K. Sokolowski-Tinten and J. Bialkowski, "Laser-solid interaction in the femtosecond time regime," *Applied Surface Science*, vol. 109, no. 110, pp. 1-10, 1997.



AFOSR/JTO MRI Annual Report 2016

Townes Laser Institute - College of Optics & Photonics –

University of Central Florida



excess of the 10^{16} W/cm² electron density obtained within the filament core, enabling the generation of transient currents far greater than those found within the filament core and consequently far stronger radio frequency emissions.

RF radiation from filament-matter interaction can be further enhanced by using a lens to prepare the laser filament. In addition to improving shot to shot stability, a spherical lens will refract the peripheral field of a filament onto the optical axis at the lens focal plane, temporarily enhancing on-axis beam irradiances along with electron emission responsible for RF radiation. This can be used to ensure the peak electric field of the filament exceeds the breakdown threshold of irradiated solids.

4.2.1 RF Generation Model

The generation of RF radiation from laser solid interactions was modeled numerically using MATLAB. In the model, incident laser radiation is assumed to ionize the surface of irradiated matter through a combination of multi-photon ionization and avalanche ionization, resulting in the generation of free electrons. The electrons were then assumed to stream directly away from the surface at the electron thermal velocity, until their momentum was arrested by collisions with neutral air molecules. This results in a short distance, transient current which acts as a broadband dipole radiator.

The electron dynamics resulting from laser-matter interaction can be expressed as a series of differential equations, which can be numerically solved using the Euler method. Before evaluating electron dynamics, the time and space resolved incident irradiance was determined. To obtain the irradiance, the incident laser pulse was assumed to be Gaussian in both space and time, and the pulse was assumed to be cylindrically symmetric. Departures from Gaussian behavior in space were accounted for using an above unity M^2 factor. Departures from Gaussian behavior in time, usually resulting from chirp, were accounted for by increasing the beam temporal pulse duration to match the temporal pulse broadening associated with the pulse chirp.

In the 5th annual year report we outlined in detail, our new analytical model of RF generation in filament laser plasmas, together with the building blocks of the numerical model used in our studies. We see no need to reproduce this model here.

4.2.2 RF detection and measurement

Given the duration of the laser pulses used to drive the plasma responsible for RF radiation, and the temporary duration of the resulting plasma, resulting RF radiation is expected to be short lived and broadband. For these reasons, single-shot, broadband measurements are required to evaluate the RF radiation. To carry out such measurements, a Tektronix CSA7404 was used, which is a single-shot oscilloscope with a 4 GHz bandwidth and 20 GS/s sample rate. The instrumentation used, and the methodology employed to deduce the amplitude and spectrum of the RF emission generated has been described in this report and previous reports.



AFOSR/JTO MRI Annual Report 2016
Townes Laser Institute - College of Optics & Photonics –
University of Central Florida



5.0.0 Educational and Career-building impacts of this program.

The progress and research involved with this program in the five years from 2011 to 2015 has significantly advanced the careers of several of the principal scientists centrally or peripherally involved in the project.

5.1.0 Senior scientific personnel

Dr Matthieu Baudelet started this project as a Assistant Research Professor. In 2014 he has appoint to a tenure-track Assistant Professor position in the Dept. of Chemistry and the National Center for Forensic Science (NCFS) at UCF.

Dr Magali Durand joined this program as a Research Scientist and lead scientist of the Filamentation Team in 2012. She returned to France in 2014 as a senior research engineer for Amplitude Systemes in Pessac, Bordeaux.

Dr Michael Chini join the program as a Research Scientist and as lead scientist for Ultrafast Laser Development in 2014. In 2015 he was appointed to a tenure-track Assistant Professor in the Physics Dept. at UCF.

Dr Nicholas Barbieri gained his Ph.D in this program 2014, and remained as a scientist in the Filamentation Team until 2015. He has since joined the Sensors and Systems Directorate at Army Research Labs in Adelphi, Md, as a scientist.

Dr Shermineh Rostami-Fairchild joined the program towards its end in 2015. She is still closely involved as the Team Leader for Filamentation. In the summer of 2107, she will assume a position as an Assistant Professor in the Physics Dept. at the Florida Institute of Technology in Melbourne, FL. She will still maintain an active role in the current Filamentation Program.

Dr Lawrence Shah has been the lead in high power fiber laser development, with a strong involvement the Filamentation program throughout the time of this contract. He was initially a senior Scientist, then an Assistant Research Professor during the time of this program. Recently he has taken a full-time position with Luminar Inc, a new startup laser company in Orlando.

5.2.0 Graduate students

Many students obtained M.S. and Ph.D students in LPL during the term of this contract. A partial list is attached below:

75 CHEONHA JEON [KR] Ph.D (Optics) University of Central Florida

2012 -

2016

“Laser filament interaction with aerosols and clouds”



AFOSR/JTO MRI Annual Report 2016
Townes Laser Institute - College of Optics & Photonics –
University of Central Florida



MS (Optics) University of Central Florida (non-thesis) <i>Scientist, Gwangju Institute of Science & Technology, Korea</i>	2010 -2012
74 BENJAMIN WEBB [US] Ph.D (Optics) University of Central Florida “Design and engineering of ultrafast amplifier systems” MS (Optics) University of Central Florida (non-thesis) <i>Scientist, University of Rochester, LLE, Rochester, NY, USA</i>	2011 - 2016 2009 - 2011
73 ETHAN LANE [US] M.S. (ECE) University of Central Florida (non-thesis) <i>Engineer, LPL, College of Optics, UCF</i>	2014-2016
72 ROBERT RYAN [US] M.S. (Optics) University of Central Florida (non-thesis) <i>(part-time)</i> <i>Engineer, Lockheed Martin Corp, Orlando</i>	2013-2016
71 DANIEL KEPLER [US] M.S. (Optics) University of Central Florida “Coupling of laser beams for filament propagation” <i>Development engineer, Northrop-Grumman Corp, Melbourne, Florida</i>	2014-2016
70 KHAN LIM [SG] Ph.D (Optics) University of Central Florida “Investigative study of laser filamentation in different conditions” MS (Optics) non-thesis University of Central Florida <i>Research Scientist, Singapore Defense Science & Technology Agency, Singapore</i>	2010 - 2014 2009 -2010
69 YUSEONG JANG [KR] MS (Optics) University of Central Florida “High-resolution time-resolved imaging system in the vacuum ultraviolet region” <i>Development Engineer, KLA- Tencor, Korea</i>	2012 -2014
68 ERIK MCKEE [US] MS (Optics) University of Central Florida “Femtosecond filament interaction as a probe for molecular alignment” <i>Engineer, Trumpf USA, Farmington Conn.</i>	2012 -2014
67 CHRISTINA WILLIS [US] Ph.D (Optics) University of Central Florida “Ytterbium-doped fiber-seeded thin-disk master oscillator power amplifier laser system” MS (Optics) non-thesis University of Central Florida <i>Research Scientist in Lasers Fibertek Inc, Herndon, Virginia 20171 (cccwillis@gmail.com)</i>	2010 - 2013 2008 - 2010
66 ANDREAS VAUPEL [DE] Ph.D (Optics) University of Central Florida “Development on Optical Parametric Chirped-Pulse Amplification at High Average Power and High Pulse Energy” MS (Optics) non-thesis University of Central Florida <i>Laser Engineer, IPG Lasers, Conn.</i>	2010 - 2013 2008 - 2010
55 NICHOLAS BARBIERI [US] Ph.D (Physics) University of Central Florida “Engineering and application of ultrafast laser pulses and filamentation in air” MS (Physics) University of Central Florida “Measurement and characterization of microwave transient electromagnetic fields generated from laser/matter interaction” <i>Scientist, Laser Plasma Laboratory, Townes Laser Institute, University of Central Florida</i>	2008 – 2012 2004 – 2005
54 MATTHEW WEIDMANN [US] Ph.D (Optics) University of Central Florida “Laser filamentation interaction with materials for spectroscopic applications” MS (Optics) non-thesis University of Central Florida <i>Research scientist, Max Planck Institute for Quantum Optics, Munich matthew.weidman@mpq.mpg.de</i>	2008 - 2012 2006 - 2007



AFOSR/JTO MRI Annual Report 2016
Townes Laser Institute - College of Optics & Photonics –
University of Central Florida



Within the Filamentation Team those students graduating during the term of this contract included:

Nicholas Barbieri [US citizen] MS and Ph.D (Physic) with a thesis, “Engineering and application of ultrafast laser pulses and filamentation in air”. He is now a scientist in the sensors and systems directorate at the Army Research Laboratories at Adelphi, MD.

Matthew Weidmann [US citizen] M.S and Ph.D degrees, with a thesis, entitled, “Laser filamentation interaction with materials for spectroscopic applications”. He currently is a scientist at the Max Planck Institute for Quantum Optics in Garching, Germany.

Erik McKee [US citizen] MS (Optics) entitled, “Femtosecond filament interaction as a probe for molecular alignment” in 2014. He now works for Trumpf USA, a large high power laser company.

Khan Lim [Singaporean citizen] MS and Ph.D (Optics), thesis title, “Investigative study of laser filamentation in different conditions”. He joined the Filamentation Team as a funded student from the Singapore Defense Science Organization (DSO) and returned there in 2014.

Daniel Kepler [US citizen] MS (Optics) “Coupling of laser beams for filament propagation”. He now is employed by Northrop Grumman Corp. in Melbourne FL.

Ethan Lane [US citizen] MS (Optics), was a graduate student in the Filamentation program for two years. He now works for Northrop Grumman in Connecticut.

Cheon Ha Jeon [Korean citizen] MS and Ph.D (Optics) with a thesis,” “Laser filament interaction with aerosols and clouds” He joined LPL with an MS degree from Yale, and is now a senior Scientist at Gwangju Institute for Science and Technology (GIST) in Gwangju, South Korea, working on high intensity laser physics.

Also during the latter part of this program several graduate students joined the Filamentation Team at LPL, and are currently pursuing their degrees. These include:

Nathan Bodnar, [US citizen] (ECE) in ultra-high intensity laser development.

Daniel Thul [US citizen] (Optics)

Danielle Reyes [US citizen] (Physics)

Haley Kerrigan [US citizen] (Optics)

It should be noted amongst these students, the *large fraction (82%) of U.S. citizens* in the program, and in its current form, with Dr Shermineh Rostami-Fairchild, and **almost 50% gender ratio**.



AFOSR/JTO MRI Annual Report 2016
Townes Laser Institute - College of Optics & Photonics –
University of Central Florida



5.3.0 Publications resulting from this contract.

Below is a partial list. It should be recognized that manuscripts are still in preparation and more papers will be submitted for publication in the future.

5.3.1 Book Chapters

2015 In preparation with Wiley: A multiple author book on “Filament Science”, co-edited by Jean-Claude Diels, Martin Richardson and Ladan Arissian.

2016 “Filamentation, third harmonic and supercontinuum generation, conical emission in the anomalous dispersion region of transparent solids”, A. Couairon, V. Jukna, J. Darginavicius, D. Majus, N. Garejev, I. Grazuleviciute, G. Valiulis, G. Tamosauskas, A. Dubietis, F. Silva, D.R. Austin, M. Hemmer, M. Baudisch, A. Thai, J. Biegert, D.Faccio, A.Jarnac, A. Houard, Y. Liu, A. Mysyrowicz, S. Grabielle, N. Forget, A.Durécu, M. Durand, K. Lim, E. McKee, M. Baudelet, M. Richardson, Editors: Andre D. Bandrauk, Emmanuel Lorin, Jerome V. Moloney Laser Filamentation - Mathematical Methods and Models, Part of the series CRM Series in Mathematical Physics pp 147-165, 2016

5.3.2 Journal publications

2016

‘Characterization of LAM-fabricated Porous superalloys for turbine components’.B. Early, L. Calderon, W. Wang, R. Valentin, I. Mingareev, & J. Kapat , Journal of Engineering for Gas Turbines and Power

"Principles and applications of trans-wafer processing using a 2- μ m thulium fiber laser"

I. Mingareev, N. Gehlich, T. Bonhoff, A. Abdulfattah, A.M. Sincore, P. Kadwani, L. Shah, and M.C. Richardson
International Journal of Advanced Manufacturing, 84 (9), pp.2567-2578

“Dramatic enhancement of supercontinuum generation in elliptically-polarized laser filaments” S. Rostami, M. Chini, K. Lim, J. Palestro, M. Durand, J-C Diels, L. Arissian, M. Baudelet & M. Richardson, Nature Scientific Reports

"Beam propagation of Gaussian and annular beams at 2 μ m in presence of thermal lensing", A. Sincore, J. Cook, W. Li, E. Johnson, J. Bradford, L. Shah, and M.C. Richardson, Conference on Lasers and Electro-Optics (CLEO), Science and Innovations, paper JTh2A.77

“Directly laser-written integrated photonics devices including diffractive optical elements”

Jiyeon Choi, Mark Ramme, and Martin Richardson Optics & Lasers in Engineering, Elsevier.

“Divided-pulse amplification to the joule level,” B. Webb, A. Azim, N. Bodnar, M. Chini, L. Shah, M. Richardson, Optics Letters 41, 13 (2016) 3106-3109

“Fabrication of computer generated holograms using femtosecond laser direct writing”



AFOSR/JTO MRI Annual Report 2016
Townes Laser Institute - College of Optics & Photonics –
University of Central Florida



R. Berlich, D. Richter, M. Richardson and S. Nolte, *Opt. Lett.* 41(8), 1752-1755 (2016)

2015

High-power spectral beam combining of linearly polarized Tm: fiber lasers", L. Shah, R.A. Sims, P. Kadwani, C.C.C. Willis, J.B. Bradford, A. Sincore, M. Richardson, *Applied Optics* 54(4), pp.757-762 (2105)

Interaction of a single laser filament with a single droplet of water", C. Jeon, D. Harper¹, K. Lim, M. Durand, M. Chini, M. Baudelet, & M. Richardson, *Jnl. of Optics* (2015)

Silicon processing using a nanosecond 2 μm Tm: fiber laser, Tobias Bonhoff, Ashraf F. El-Sherif, Thomas Ferhat, Mark Ramme, Pankaj Kadwani, Christina Willis, Ilya Mingareev, Lawrence Shah, and Martin Richardson *Opt. Lett.* (submitted for publication)

Angular dependence of filament-induced plasma emission from a GaAs surface", Matthew Weidman, Mark Ramme, Bruno Bousquet, Khan Lim, Magali Durand, Matthieu Baudelet, Martin Richardson *Opt. Lett.* 40, 4548-4551 (2015)

Evaluating Study of Ultrafast Laser-Assisted Cleaning of Historical Textiles Conservation", H. E. Ahmed, Amal A. El-Ebissy, I. Mingareev, M. Richardson, *J. Textile and Apparel, Technology and Management*, 9, 2 (2015)

Examination of laser-induced heating on multi-component chalcogenide glass", L. Sisken, N. Gerlich, J.D. Bradford, A.Q. Abdulfattah, L. Shah, M.C. Richardson, K. Richardson *SPIE Infrared Technology and Application XL 2014*, paper 9070-1A

All-fiber Thulium-doped PCF Amplifier", Alex Sincore, Lasse Leick, Lawrence Shah, and Martin Richardson Elsevier Editorial System(tm) (for Optics & Laser Technology (to be published)

Rapid thermo-optical quality assessment of laser gain media", C.C. Willis, J. D Bradford¹, J. Haussermann, E. McKee, E. Maddox, L. Shah, R. Gaume, & M. Richardson, (*Optical Materials Express* 5(6), pp.1389-1398, 2015

444 ***High-power spectral beam combining of linearly polarized Tm: fiber lasers***", L. Shah, R.A. Sims, P. Kadwani, C.C.C. Willis, J.B. Bradford, A. Sincore, M. Richardson, *Applied Optics* 54, 1 (2015) 757-762

2014

443 ***Comparative study of light propagation and single-mode operation in large-mode area fibers designed for 2 microns laser applications***", Clemence Jollivet, Bryce Samson, Lasse Leick, Lawrence Shah, Martin Richardson & Axel Schulzgen, *Optical Engineering*, vol. 54, no. 1, 011006 (2014)

442 ***Study of Filamentation Threshold in Zinc Selenide***" Magali Durand, Aurélien Houard, Khan Lim, Anne Durécu, Olivier Vasseur, Martin Richardson, *Optics Express* 22, 5852-5858 (2014)



AFOSR/JTO MRI Annual Report 2016
Townes Laser Institute - College of Optics & Photonics –
University of Central Florida



- 441 **"Helical filaments"**, N. Barbieri, Z. Hosseinimakarem, K. Lim, M. Durand, M. Baudelet, E. Johnson, & M. Richardson, Appl. Phys. Lett. 104(26), pp. 261109 (2014)
- 440 **"Comparison between geometrically focused pulses versus filaments in femtosecond laser ablation of steel and titanium alloys"**, A Valenzuela, C Munson, A Porwitzky, M Weidman, and M Richardson, Appl. Phys. B- Lasers And Optics 116(2), pp. 485-491 (2014)
- 439 **"Transition from linear- to nonlinear-focusing regime in filamentation."** K. Lim, M. Durand, M. Baudelet, M. Richardson, Nature Sci. Rep. 4, 7217; DOI:10.1038/ srep07217 (2014).
- 438 **"Studying the effect of zeolite inclusion in aluminum alloy on measurement of its surface hardness using laser-induced breakdown spectroscopy technique"**, O. Khalil, I. Mingareev, T. Bonhoff, A.F. El-Sherif, M.C. Richardson, M.A. Harith, Opt. Eng., 53(1), 014106 (2014)
- 437 **"Spatiotemporal cleaning of a femtosecond laser pulse through interaction with counterpropagating filaments in air"**, A. Jarnac, M. Durand, A. Houard, Y. Liu, B. Prade, M. Richardson, and A. Mysyrowicz, Phys. Rev. A 89,023844, 1-4 (2014)
- 436 **"High peak-power mid-infrared ZnGeP₂ optical parametric oscillator pumped by a Tm: fiber master oscillator power amplifier system"**, Martin Gebhardt, Christian Gaida, Pankaj Kadwani, Alex Sincore, Nils Gehlich, Cheonha Jeon, Lawrence Shah, and Martin Richardson, Optics Letts. 39, 5 / March 12014
- 435 **"Concepts, performance review, and prospects of table-top, few-cycle optical parametric chirped-pulse amplification"**, Andreas Vaupel, Nathan Bodnar, Benjamin Webb, Lawrence Shah, & Martin Richardson, SPIE. Optical Engineering 53(5), 051507-12 (May 2014)

2013

- 434 **"A hybrid MOPA system providing 10 mJ, 32 W, and 50 MW pulses for OPCPA pumping"**, Andreas Vaupel, Nathan Bodnar, Benjamin Webb, Lawrence Shah, Michaël Hemmer, Eric Cormier, and Martin Richardson, JOSA B Vol.30, No. 12 Dec 2013
- 433 **"1 uJ, sub-500 fs chirped pulse amplification in a Tm-doped fiber system"**, R.A. Sims, P. Kadwani, A. Sincore, L. Shah, M. Richardson, Opt. Lett. 38, 121-123 (2013)
- 432 **"Fabrication and Analysis of Porous Superalloys for Turbine Components Using Laser Additive Manufacturing"** Bernstein, Josh A., Anthony Bravato, Brandon Ealy, Mark Ricklick, J. S. Kapat, Ilya Mingareev, Martin Richardson, Wilhelm Meiners, and Ingomar Kelbassa, Proc. of 49th AIAA/ASME/SAE/ASEE Joint Propulsion Conference, San Jose, CA (2013)
- 431 **"Femtosecond Laser Post-Processing of Metal Parts Produced by Laser Additive Manufacturing"**, Ilya Mingareev, Martin Richardson, Tobias Bonhoff, Ashraf F. El-Sherif, Jnl. Laser Applications, J. Laser Applications, vol. 25 (5), 052009 (2013)
- 430 **"Highly polarized all-fiber thulium laser with femtosecond-laser-written fiber Bragg gratings "**, Christina C. Willis, Erik McKee, Pascal Böswetter, Alex Sincore, Jens Thomas, Christian Voigtländer, Ria G. Krämer, Joshua



AFOSR/JTO MRI Annual Report 2016
Townes Laser Institute - College of Optics & Photonics –
University of Central Florida



- D. Bradford, Lawrence Shah, Stefan Nolte, Andreas Tünnermann, and Martin Richardson, *Optics Express* Vol. 21, Iss. 9, pp. 10467–10474 (2013)
- 429 **“Laser-plasma source parameters for Kr, Gd, and Tb ions at 6.6 nm”**, Majid Masnavi, John Szilagy, Homaira Parchamy, and Martin C. Richardson, *Appl. Phys. Lett.* 102, 16, 164102 (2013)
- 428 **“Blueshifted continuum peaks from filamentation in the anomalous dispersion regime”**, Magali Durand, Khan Lim, Vytautas Jukna, Erik McKee, Matthieu Baudelet, Aurélien Houard, Martin Richardson, André Mysyrowicz, Arnaud Couairon, *Phys. Rev. A* 87, 043820 (2013)
- 427 **“Virtual hyperbolic metamaterials for manipulating radar signals in air”**, Zhaxylyk A. Kudyshev, Martin C. Richardson, Natalia M. Litchinitser, *Nature Communications* 4, Article number: 2557 (2013)
- 426 **“Investigation of Historical Egyptian Textile using Laser-Induced Breakdown Spectroscopy (LIBS) - a case study”** Harby Ezzeldeen Ahmed, Yuan Liu, Matthieu Baudelet, Bruno Bousquet, Martin Richardson, *Jnl. Textile & Apparel, Techn. & Managmt* 8(2) (2013)
- 425 **“Amplification of nanosecond pulses to megawatt peak power levels in Tm³⁺-doped photonic crystal fiber rod”**, Christian Gaida, Martin Gebhardt, Pankaj Kadwani, Lasse Leick, Jes Broeng, Lawrence Shah, Martin Richardson, *Opt. Lett.*, vol. 38, no. 5, p. 691-693
- 424 **“1 uJ, sub-500 fs chirped pulse amplification in a Tm-doped fiber system”**, R.A. Sims, P. Kadwani, A. Sincore, L. Shah, M. Richardson, *Opt. Lett.* vol. 38, no. 2, pp. 121-12
- 423 **“Chirped pulse amplification in single mode Tm: fiber using a chirped Bragg grating”**, R. Andrew Sims, Pankaj Kadwani, Alex Sincore, Lawrence Shah, Martin Richardson, *Appl. Phys. B* DOI 10.1007/s00340-013-5333-5, January 24, 2013
- 2012**
- 422 **“Discriminant Analysis in the Presence of Interferences: Combined Application of Target Factor Analysis and a Bayesian Soft-Classifer”**, Caitlin N Rinke, Mary R Williams, Christopher Brown, Matthieu Baudelet, Martin Richardson, Michael E. Sigman, *Analytica Chimica Acta* 753, 19– 26 (2012)
- 421 **“Evolution of hole shape and size during short and ultrashort pulse laser deep drilling”**, Sven Döring, John Szilagy, Sören Richter, Felix Zimmermann, Martin Richardson, Andreas Tünnermann, Stefan Nolte, *Optics Express*, Vol. 20 Issue 24, pp.27147-27154 (2012)
- 420 **“Spatially resolved measurement of femtosecond laser induced refractive index changes in transparent materials”**, René Berlich Jiyeon Choi, Clarisse Mazuir, Winston V. Schoenfeld, Stefan Nolte, and Martin Richardson, *Optics Letters* (accepted for publication) 2012
- 419 **“Correlation between laser-induced breakdown spectroscopy signal and moisture content”**, Yuan Liu, Lionel Gigant, Matthieu Baudelet, Martin Richardson, *Spectrochimica Acta, B*, 70, 71-74 (2012)
- 418 **“Integrated Tm: fiber MOPA with polarized output and narrow linewidth with 100 W average power”** Lawrence Shah, R. Andrew Sims, Pankaj Kadwani, Christina C.C. Willis, Joshua B. Bradford, Zachary Roth, Aaron Pung, Menelous Poutous, Eric G. Johnson, & Martin Richardson (submitted for publication)
- 417 **“Lasing in thulium-doped rod type PCF”**, C. Gaida, P. Kadwani, L. Leick, J. Broeng, L. Shah, & M. Richardson, *Optics Letters*, vol. 37, no. 21, pp. 4513-4515 (2012)
- 416 **“Comparison of Higher-Order Mode Suppression and Q-Switched Laser Performance in**



AFOSR/JTO MRI Annual Report 2016
Townes Laser Institute - College of Optics & Photonics –
University of Central Florida



- Thulium-doped Large Mode Area and Photonic Crystal Fibers**", P. Kadwani, C. Jollivet, R. Andrew Sims, Axel Schülzgen, Lawrence Shah, and Martin Richardson, (submitted for publication)
- 415 **"Modal Properties of Photonic Crystal Fiber for High Power 2 Micron Fiber Laser Systems"**, A. Schülzgen, C. Jollivet Salvin, R. A. Sims, P. Kadwani, L. Shah, M.C. Richardson, R. Amezcua Correa, T. T. Alkeskjold, and L. Leick, Proc. SPIE 8381-4 (2012)
- 414 **"Moisture Measurement Using LIBS"**, Y. Liu, M. Baudelet, M. Richardson, G.I.T. Laboratory Journal Europe (June, 2012)
- 414 **"Multispectral optical tweezers for molecular diagnostics of single biological cells"**, C. Butler, S. Fardad, A. Sincore, M. Vangheluwe, M. Baudelet, M. Richardson, Proc. of SPIE Vol. 8225 82250C-1 (2012)
- 413 **"OPCPA pump laser based on a regenerative amplifier with volume Bragg grating spectral filtering"**, M. Hemmer, A. Vaupel, M. Wohlmuth, and M. Richardson, Appl. Phys. B: Lasers & Optics 106(3), pp.599-603, (2012)
- 412 **"Welding of polymers using a 2 μm thulium fiber laser"**, I. Mingareev, F. Weirauch, A. Olowinsky, L. Shah, P. Kadwani, M. Richardson, J. Opt. Laser Technol. 44, pp. 2095-2099
- 411 **"Transparent ceramics for lasers - A game-changer"**, M. Richardson and R. Gaume, American Ceramic Society Bulletin, 91, 4 May 2012
- 410 **"Stand-off filament-induced ablation of Gallium Arsenide"**, Matthew Weidman, Khan Lim, Mark Ramme, Magali Durand, Matthieu Baudelet & Martin Richardson, Appl. Phys. Lett. 101, 034101 (2012)
- 409 **"Improvement of the sensitivity for the measurement of copper concentrations in soil by microwave-assisted laser-induced breakdown spectroscopy"**, Yuan Liu, Bruno Bousquet, Matthieu Baudelet, Martin Richardson, Spectrochimica Acta, 2012), doi:10.1016/j.sab.2012.06.041
- 408 **"Three-dimensional direct femtosecond laser writing of second-order nonlinearities in glass"**, Jiyeon Choi, Matthieu Bellec, Arnaud Royon, Kevin Bourhis, Gautier Papon, Thierry Cardinal, Lionel Canioni, and Martin Richardson Opt. Lett. Optics Letters 37(6), pp.1029-1031, (2012)
- 407 **"Sub-5-ps linewidth, 130-nm-tuning of a coupled-cavity Ti:sapphire oscillator via volume Bragg grating-based feedback"**, Michael Hemmer, Andreas Vaupel, Martin Richardson, Applied Physics B-Lasers And Optics 106(4), pp.803-807, 2012.
- 406 **"Transverse mode competition in gain-guided index antiguided fiber lasers"**, Xiangru Wang, Ying Chen, William Hageman, Gyu Ug Kim, Martin Richardson, Caidong Xiong, John Ballato, Michael Bass, Jnl Opt. Soc. Am., SA B Vol. 29, 2, pp. 191–196, (2012)
- 405 **"OPCPA pump laser based on a regenerative amplifier with volume Bragg grating spectral filtering"**, Michael Hemmer, Andreas Vaupel, Matthias Wohlmuth, Martin Richardson, Appl. Phys. B. 10.1007 /s00340-011-4843-2. 14 January (2012)
- 404 **"Advances in Intense Femtosecond Laser Filamentation in Air"**, S. L. Chin, J. Wang, C. Marceau, J. Wu, J. S. Liu, O. Kosareva, N. Panov, Y. P. Chen, F. Daigle, S. Yuan, A. Azarm, W. W. Liu, T. Seideman, H. P. Zeng, M. Richardson, R. Lic, and Z. Z. Xu, Laser Physics, 2012, Vol. 22, No. 1, pp. 1–53.

2011

"Dramatic enhancement of supercontinuum generation in elliptically-polarized laser filaments" S. Rostami, M. Chini, K. Lim, J. Palestro, M. Durand, J-C Diels, L. Arissian, M. Baudelet & M. Richardson, Nature Scientific Reports

"Directly laser-written integrated photonics devices including diffractive optical elements" Jiyeon Choi, Mark Ramme, and Martin Richardson Optics & Lasers in Engineering, Elsevier.



AFOSR/JTO MRI Annual Report 2016
Townes Laser Institute - College of Optics & Photonics –
University of Central Florida



“Divided-pulse amplification to the joule level,” B. Webb, A. Azim, N. Bodnar, M. Chini, L. Shah, M. Richardson, *Optics Letters* 41, 13 (2016) 3106-3109

“Fabrication of computer generated holograms using femtosecond laser direct writing”, R. Berlich, D. Richter, M. Richardson and S. Nolte, *Opt. Lett.* 41(8), 1752-1755 (2016)

2015

“Interaction of a single laser filament with a single droplet of water”, C. Jeon, D. Harper¹, K. Lim, M. Durand, M. Chini, M. Baudelet, & M. Richardson, *Jnl. of Optics* (2015)

“Angular dependence of filament-induced plasma emission from a GaAs surface”, Matthew Weidman, Mark Ramme, Bruno Bousquet, Khan Lim, Magali Durand, Matthieu Baudelet, Martin Richardson *Opt. Lett.* 40, 4548-4551 (2015)

***“Evaluating Study of Ultrafast Laser-Assisted Cleaning of Historical Textiles Conservation”*,** H. E. Ahmed, Amal A. El-Ebissy, I. Mingareev, M. Richardson, *J. Textile and Apparel, Technology and Management*, 9, 2 (2015)

442 **“Study of Filamentation Threshold in Zinc Selenide”** Magali Durand, Aurélien Houard, Khan Lim, Anne Durécu, Olivier Vasseur, Martin Richardson, *Optics Express* 22, 5852-5858 (2014)

441 **“Helical filaments”,** N. Barbieri, Z. Hosseinimakarem, K. Lim, M. Durand, M. Baudelet, E. Johnson, & M. Richardson, *Appl. Phys. Lett.* 104(26), pp. 261109 (2014)

440 **“Comparison between geometrically focused pulses versus filaments in femtosecond laser ablation of steel and titanium alloys”,** A Valenzuela, C Munson, A Porwitzky, M Weidman, and M Richardson, *Appl. Phys. B-Lasers And Optics* 116(2), pp. 485-491 (2014)

439 **“Transition from linear- to nonlinear-focusing regime in filamentation.”** K. Lim, M. Durand, M. Baudelet, M. Richardson, *Nature Sci. Rep.* 4, 7217; DOI:10.1038/ srep07217 (2014).

437 **“Spatiotemporal cleaning of a femtosecond laser pulse through interaction with counterpropagating filaments in air”,** A. Jarnac, M. Durand, A. Houard, Y. Liu, B. Prade, M. Richardson, and A. Mysyrowicz, *Phys. Rev. A* 89,023844, 1-4 (2014)

435 **“Concepts, performance review, and prospects of table-top, few-cycle optical parametric chirped-pulse amplification”,** Andreas Vaupel, Nathan Bodnar, Benjamin Webb, Lawrence Shah, & Martin Richardson, *SPIE. Optical Engineering* 53(5), 051507-12 (May 2014)

2013

434 **“A hybrid MOPA system providing 10 mJ, 32 W, and 50 MW pulses for OPCPA pumping”,** Andreas Vaupel, Nathan Bodnar, Benjamin Webb, Lawrence Shah, Michaël Hemmer, Eric Cormier, and Martin Richardson, *JOSA B* Vol.30, No. 12 Dec 2013



AFOSR/JTO MRI Annual Report 2016
Townes Laser Institute - College of Optics & Photonics –
University of Central Florida



- 433 **"1 uJ, sub-500 fs chirped pulse amplification in a Tm-doped fiber system"**, R.A. Sims, P. Kadwani, A. Sincore, L. Shah, M. Richardson, *Opt. Lett.* 38, 121-123 (2013)
- 429 **"Laser-plasma source parameters for Kr, Gd, and Tb ions at 6.6 nm"**, Majid Masnavi, John Szilagyi, Homaira Parchamy, and Martin C. Richardson, *Appl. Phys. Lett.* 102, 16, 164102 (2013)
- 428 **"Blueshifted continuum peaks from filamentation in the anomalous dispersion regime"**, Magali Durand, Khan Lim, Vytautas Jukna, Erik McKee, Matthieu Baudelet, Aurélien Houard, Martin Richardson, André Mysyrowicz, Arnaud Couairon, *Phys. Rev. A* 87, 043820 (2013)
- 427 **"Virtual hyperbolic metamaterials for manipulating radar signals in air"**, Zhaxylyk A. Kudyshev, Martin C. Richardson, Natalia M. Litchinitser, *Nature Communications* 4, Article number: 2557 (2013)
- 426 **"Investigation of Historical Egyptian Textile using Laser-Induced Breakdown Spectroscopy (LIBS) - a case study"** Harby Ezzeldeen Ahmed, Yuan Liu, Matthieu Baudelet, Bruno Bousquet, Martin Richardson, *Jnl. Textile & Apparel, Techn. & Managmt* 8(2) (2013)
- 425 **"Amplification of nanosecond pulses to megawatt peak power levels in Tm³⁺-doped photonic crystal fiber rod"**, Christian Gaida, Martin Gebhardt, Pankaj Kadwani, Lasse Leick, Jes Broeng, Lawrence Shah, Martin Richardson, *Opt. Lett.*, vol. 38, no. 5, p. 691-693
- 424 **"1 uJ, sub-500 fs chirped pulse amplification in a Tm-doped fiber system"**, R.A. Sims, P. Kadwani, A. Sincore, L. Shah, M. Richardson, *Opt. Lett.* vol. 38, no. 2, pp. 121-12
- 423 **"Chirped pulse amplification in single mode Tm: fiber using a chirped Bragg grating"**, R. Andrew Sims, Pankaj Kadwani, Alex Sincore, Lawrence Shah, Martin Richardson, *Appl. Phys. B DOI* 10.1007/s00340-013-5333-5, January 24, 2013
- 2012**
- 422 **"Discriminant Analysis in the Presence of Interferences: Combined Application of Target Factor Analysis and a Bayesian Soft-Classifer"**, Caitlin N Rinke, Mary R Williams, Christopher Brown, Matthieu Baudelet, Martin Richardson, Michael E. Sigman, *Analytica Chimica Acta* 753, 19– 26 (2012)
- 421 **"Evolution of hole shape and size during short and ultrashort pulse laser deep drilling"**, Sven Döring, John Szilagyi, Sören Richter, Felix Zimmermann, Martin Richardson, Andreas Tünnermann, Stefan Nolte, *Optics Express*, Vol. 20 Issue 24, pp.27147-27154 (2012)
- 420 **"Spatially resolved measurement of femtosecond laser induced refractive index changes in transparent materials"**, René Berlich Jiyeon Choi, Clarisse Mazuir, Winston V. Schoenfeld, Stefan Nolte, and Martin Richardson, *Optics Letters* (accepted for publication) 2012
- 419 **"Correlation between laser-induced breakdown spectroscopy signal and moisture content"**, Yuan Liu, Lionel Gigant, Matthieu Baudelet, Martin Richardson, *Spectrochimica Acta, B*, 70, 71-74 (2012)
- 414 **"Moisture Measurement Using LIBS"**, Y. Liu, M. Baudelet, M. Richardson, *G.I.T. Laboratory Journal Europe* (June, 2012)
- 414 **"Multispectral optical tweezers for molecular diagnostics of single biological cells"**, C. Butler, S. Fardad, A. Sincore, M. Vangheluwe, M. Baudelet, M. Richardson, *Proc. of SPIE Vol. 8225 82250C-1* (2012)



AFOSR/JTO MRI Annual Report 2016
Townes Laser Institute - College of Optics & Photonics –
University of Central Florida



- 413 **"OPCPA pump laser based on a regenerative amplifier with volume Bragg grating spectral filtering"**, M. Hemmer, A. Vaupel, M. Wohlmuth, and M. Richardson, Appl. Phys. B: Lasers & Optics 106(3), pp.599-603, (2012)
- 410 **"Stand-off filament-induced ablation of Gallium Arsenide"**, Matthew Weidman, Khan Lim, Mark Ramme, Magali Durand, Matthieu Baudelet & Martin Richardson, Appl. Phys. Lett. 101, 034101 (2012)
- 409 **"Improvement of the sensitivity for the measurement of copper concentrations in soil by microwave-assisted laser-induced breakdown spectroscopy"**, Yuan Liu, Bruno Bousquet, Matthieu Baudelet, Martin Richardson, Spectrochimica Acta, 2012), doi:10.1016/j.sab.2012.06.041
- 408 **"Three-dimensional direct femtosecond laser writing of second-order nonlinearities in glass"**, Jiyeon Choi, Matthieu Bellec, Arnaud Royon, Kevin Bourhis, Gautier Papon, Thierry Cardinal, Lionel Canioni, and Martin Richardson Opt. Lett. Optics Letters 37(6), pp.1029-1031, (2012)
- 405 **"OPCPA pump laser based on a regenerative amplifier with volume Bragg grating spectral filtering"**, Michael Hemmer, Andreas Vaupel, Matthias Wohlmuth, Martin Richardson, Appl. Phys. B. 10.1007/s00340-011-4843-2. 14 January (2012)
- 404 **"Advances in Intense Femtosecond Laser Filamentation in Air"**, S. L. Chin, J. Wang, C. Marceau, J. Wu, J. S. Liu, O. Kosareva, N. Panov, Y. P. Chen, F. Daigle, S. Yuan, A. Azarm, W. W. Liu, T. Seideman, H. P. Zeng, M. Richardson, R. Lic, and Z. Z. Xu, Laser Physics, 2012, Vol. 22, No. 1, pp. 1–53.

5.3.4 Invited, Tutorial and Keynote Talks given on Filamentation during this contract

2016

- 148 **"New paradigms in laser-based remote sensing"**, Andrew Main Lecture, D.B. Robinson Distinguished Speaker Series 2016-2017, Chemical and Materials Engineering at University of Alberta, Edmonton., **October 27th**
- 147 **"Picosecond Streak-Imaging in Laser Research - from the past to the future"** Mikhail .Ya. Schelev Martin Richardson, A eulogy for Mischa Schelev who died Sept 5, 2017, 31st International Congress on High-speed Imaging and Photonics, Osaka, Japan November 2016
- 145 **"Long distance propagation studies of high power laser beams"**, M. Richardson, C. Jeon, E. Lane, M. Baudelet, L. Shah, R. Phillips, L. Andrews R. Crabbs, SPIE Security + Defense, Conference 9990, High Power Lasers – Systems and Technologies, Edinburgh, Scotland, September 2016
- 144 **"Ultrafast Laser Filamentation in Air"** M. Richardson, M. Baudelet, S. Rostami-Fairchild, Ch. Jeon & L. Shah, SPIE Security + Defense, Conference 9989 Technologies for Optical Countermeasures, Edinburgh, Scotland, September 2016
- 141 **"Laser induced filament propagation through adverse conditions"**, Ch.Jeon, E. Lane, S. Rostrami, M. Baudelet, L. Shah, M. Richardson, Propagation Through and Characterization of Atmospheric and Oceanic Phenomena, pcAOP, Washington D.C. June 2016
- 140 **"The Future of Lasers - that is High Power"** Keynote speech, Annual Meeting of the Centre d'Optique, Photonique et Laser, Laval University, Quebec City, Canada, May 23rd 2016
- 139 **"Introducing spatial phase control to high power laser beams"**, Martin Richardson, Eric Johnson, Nicholas Barbieri, Matthieu Baudelet, Shermineh Rostami, Lawrence Shah & Joshua Bradford, SPIE Photonics North, Quebec City, Canada, May 24-26th, 2016
- 138 **"Ultrafast laser filamentation in air"** M. Richardson, International Scientific Spring Workshop in Physics, National Center for Physics, Qaid-i-Azam University, Islamabad, Pakistan. April 2016
- 135 **"Long distance propagation of high power laser beams"** Martin Richardson, CheonHa Jeon, Ethan Lane, Matthieu Baudelet, Singapore Defense Sciences Organization, Singapore April 16, 2016
- 134 **"Challenges facing long distance propagation of high power laser beams"**, Martin Richardson, CheonHa Jeon, Ethan Lane, Matthieu Baudelet, High Power Laser Ablation/Directed Energy, Santa Fe, Nm, April 2016



AFOSR/JTO MRI Annual Report 2016
Townes Laser Institute - College of Optics & Photonics –
University of Central Florida



- 133 ***Single cycle laser pulses and their applications***”, Martin Richardson, Workshop on Optics & Photonics, King Abdullah University for Science & Technology, Riyadh, Feb 21 2016
- 132 ***“Light and our photonic futures”***, Martin Richardson, Public Lecture, February 17, 2016, Jazan University, Saudi Arabia
- 131 ***“The Mysteries of Ultrafast Laser Filamentation in Air”***, Martin Richardson Fifth Saudi International Meeting on Frontiers of Physics, February 16-18th, 2016, Jazan University, Saudi Arabia
- 2015**
- 129 ***Filamentation in the Air***” Martin Richardson, Seminar, Physics Dept. University of New Mexico, December 2015
- 128 ***“Extreme physics with intense single cycle laser pulses”*** Martin Richardson, 3rd ELI-ALPS User Workshop, Szeged, Hungary November 2015
- 126 ***“Photonics and the Changing Energy Scene”***, Martin Richardson, Jefferson Lecture to the National Academy of Sciences & the Dept. of State, Washington D.C. Sept 2015
- 125 ***“Fundamentals of laser interaction with water droplets”***, Cheonha Jeon, Matthieu Baudelet & Martin Richardson, 3rd Conf. on Laser Weather control, Geneva, Switzerland, Sept 2015
- 123 ***“From femtosecond laser-materials processing to 3-D printing – laser-based technologies that will transform manufacturing”***, Martin Richardson Ilya Mingareev, Stefan Nolte, Andreas Tünnermann, Ingomar Kelbassa & Reinhart Poprawe, Workshop at Korean Institute of Machinery and Materials, September 2015
- 122 ***“Laser Materials Processing and the Future”***, Martin Richardson, CLEO- Pacific Rim, Busan, Korea, September, 2015
- 121 ***“Laser Resonators and Amplifiers”*** Martin Richardson, 24th International SAOT Workshop on Lasers, Design, Modeling and Simulation of Lasers and Amplifiers”, Erlangen, Germany, June 2015
- 120 ***“New Lasers for Laser Medicine”*** Martin Richardson, ASLMS Annual Conference, Orlando, March 2015
- 119 ***“Light and our Photonics Future”***, Martin Richardson, International Scientific Spring (ISS) National Centre for Physics (NCP), Quaid-i-Azam University Campus, Islamabad, 16-20 March, 2015.
- 2014**
- 118 ***“Fundamental Studies of Laser Filament Interaction”*** Martin Richardson, Matthieu Baudelet, Tamar Seiderman, AFOSR Annual Review, Washington DC, December 2014
- 117 ***“Nonlinear Radiation Effects with Filaments - Inside and Outside”*** Martin Richardson, Magali Durand, Matthieu Baudelet, Nicholas Barbieri, Michael Chini, Khan Lim, Cheonha Jeon, Natalia Litchinitser, Zhaxylyk Kudyshev, Scott Will, Zackary Roth & Eric Johnson, OSA, Frontiers in Optics Conf. Tucson, Arizona, Oct. 2014
- 116 ***“Education in plasma spectrochemistry via LIBS for high school and undergraduate students at the Townes Laser Institute”***, Matthieu Baudelet, Romain Gaumé, Martin Richardson, Matthew Chun, Brandon Seesahai, Yuan Liu, Cheonha Jeon, NASLIBS at SciX 2014, Reno, Nevada, October 2014,
- 115 ***“The Next Generation of Filaments – Engineered Structures of Filaments”*** Nicholas Barbieri, Khan Lim, Magali Durand, Matthieu Baudelet & Martin Richardson, Zahra Hosseinimakerem, Eric Johnson, Zhaxylyk Kudyshev, Scott Will & Natalia Litchinitser, 5th Int. Symp. on Filamentation, Shanghai, Sept 20-23, 2014
- 114 ***“Spectrum and Polarization of the White-Light Supercontinuum”***, Michael Chini, Khan Lim, Magali Durand, Matthieu Baudelet, and Martin Richardson, Shermineh Rostami, Ladan Arissian, and Jean-Claude Diels, 5th Int. Symp. on Filamentation, Shanghai, Sept 20-23, 2014



AFOSR/JTO MRI Annual Report 2016
Townes Laser Institute - College of Optics & Photonics –
University of Central Florida



- 113 **“Multiple wavelengths interacting in a filament”**, Jean-Claude Diels, Ladan Arissian, Magali Durand, Matthieu Baudelet, and Martin Richardson, 5th Int. Symp. on Filamentation, Shanghai, Sept 20-23, 2014
- 112 **“Filament Propagation through Aerosols”**, Cheonha Jeon, Danielle harper, Khan lim, Magali Durand, Mike Chini, Matthieu Baudelet, Martin Richardson, 5th Int. Symp. on Filamentation, Shanghai, Sept 20-23, 2014
- 111 **“Innovations towards extending LIBS technologies”** Martin Richardson, Matthieu Baudelet, Yuan Liu, Michael Sigman, and Romain Gaume, 8th Int. Conf. on Laser Induced Breakdown Spectroscopy (LIBS 2014), Tsinghua University, Beijing,, September 8-12, 2014
- 110 **“Laser filamentation in air”** Martin Richardson, Magali Durand, Matthieu Baudelet, Nicholas Barbieri, Michael Chini, Khan Lim, Cheonha Jeon, Natalia Litchinitser, Zhaxylyk Kudyshev, Scott Will, Zackary Roth & Eric Johnson, Optical Society of Korea, Summer Meeting, Jeju Island, Korea, August, 2014
- 109 **“Light filament based free space metamaterials components”** Natalia M. Litchinitser, Zhaxylyk Kudyshev, Scott Will and Martin Richardson, SPIE Optics & Photonics Conference San Diego, August 2014
- 108 **“Filamentation, third harmonic and supercontinuum generation, conical emission in the anomalous dispersion region of transparent solids”**, Arnaud Couairon, V. Jukna, J. Darginavicius, D. Majus, N. Garejev, I. Grazuleviciute, G. Valiulis, G. Tamosauskas, A. Dubietis, F. Silva, D.R. Austin, M. Hemmer, M. Baudisch, A. Thai, J. Biegert, D.Faccio, A.Jarnac, A. Houard, Y. Liu, A. Mysyrowicz, S. Grabielle, N. Forget, A.Durécu, M. Durand, K. Lim, E. McKee, M. Baudelet, M. Richardson, Workshop on "Mathematical Methods and Models in Laser Filamentation", March 10-14, 2014, Centre de recherches mathematiques, Montreal, Canada
- 2013**
- 106 **“ Une vie avec des lasers ”** Presentation made to the University of Bordeaux 1, on the award of the *Docteur Honoris Causa*, University of Bordeaux1, Talence, France, Dec. 6th, 2013
- 105 **“Filamentation of Laser Light in Air”**, Martin Richardson, South East Section, APS, 80th Annual Meeting, Bowling Green, KE, Nov 17, 2013
- 104 **“Meta-optics transforms laser filamentation studies”**, Martin Richardson, Nicholas Barbieri, Magali Durand, Matthieu Baudelet, Eric Johnson, Zahra Hosseinimakarem, Natalia Litchinitzer, Zaxylyk Kudyshev & Richard Hammond. OSA Incubator Workshop Structured Light in Structured Media, Washington DC, Nov 17th, 2013
- 101 **“Thomson scattering from aluminum laser plasmas in air: comparison between electronic and excitation temperatures for LTE evaluation”** Yuan Liu, Bruno Bousquet, Matthieu Baudelet and Martin Richardson, 7th European-Mediterranean Symp. on Laser Induced Spectroscopy (EMSLIBS), Bari, Italy, Sept 15th – 20th, 2013
- 100 **“Thomson scattering from aluminum laser plasmas in air”**, Yuan Liu, Bruno Bousquet, Matthieu Baudelet and Martin Richardson, SciX 2013 “Fundamentals of LIBS Plasmas” – September 30th, 2013, Milwaukee, WI
- 99 **“Remote Plasmas produced by Laser Filaments”**, Martin Richardson Robert Bernath, Matthew Weidmann, Nicholas Barbieri, Khan Lim, Magali Durand and Matthieu Baudelet, . ICONO/LAT Conference, Moscow, Russia, June 18-22, 2013



AFOSR/JTO MRI Annual Report 2016
Townes Laser Institute - College of Optics & Photonics –
University of Central Florida



- 98 ***"Femtosecond Generation of Nano-Fibers"***, M. Richardson, M. Ramme, A. Royon, T. Cardinal & L. Canioni, Cargese Int. School on Ultrafast laser Modification of Materials, Cargese April 15-19, 2013, Corsica, France
- 97 ***"Recent studies of air filamentation"***, Martin Richardson, et al., Workshop on "Fundamentals and Applications of Laser Filaments" April 4th - 6th, 2013, Institute for Molecular Science (IMS), Okazaki, Japan. PLENARY TALK
- 95 ***"Laser Stand-off Sensing Technologies"***, Martin Richardson, Matthieu Baudelet, Michael Sigman and Andrzej Miziolek, Indo-US Workshop on Spectroscopy: Application to National Security, Banaras Hindu University, Varanasi, India, January 18-20, 2013
- 2012**
- 94 ***"The ARO MURI Program on Air Filamentation Science After One Year"***, Martin Richardson, Jean-Claude Diels, Alejandro Aceves, Ladan Arissian, Matthieu Baudelet, Eric Johnson, Zenghu Chang, Natalia Litchinitser, Tamar Seideman, Xie-Cheng Zhang, Richard Hammond, 10th annual ultrashort pulse laser workshop, Directed Energy Professional Society; Broomfield, CO, USA; 06/12, 2012
- 93 ***"The ARO MURI Program on Air Filamentation Science"***, M. Richardson, J. Diels, A. Aceves, L. Arissian, M. Baudelet, E. Johnson, Z. Chang, N. Litchinitser, T. Seideman, X. Zhang, and R. Hammond, COFIL 2012, Tucson, AZ, USA. Invited presentation (08 October 2012)
- 92 ***"Stand-off LIBS – The status today and the future"***, Martin Richardson, Matthieu Baudelet, Michael Sigman and Andrzej Miziolek, LIBS 2012; Luxor, Egypt; 09/29 – 10/04, 2012
- 91 ***"Stand-off chemical and biological sensing"*** M. Richardson, M. Baudelet, M. Sigman, and A. Miziolek, Frontiers in Optics 2012, Laser Science XXVIII, Rochester, NY, USA. Invited presentation (14-18 October 2012)
- 88 ***"Long range projection of high energy densities with laser filamentation and selected interaction studies"*** M. Richardson, M. Durand, M. Baudelet, M. Weidman, N. Barbieri, R. Bernath, K. Lim, 15th DEPS Annual Directed Energy Symposium, Albuquerque, Nov 27-29, 2012
- 87 ***"Fifty years of LIBS and no limits for analysis"*** Matthieu Baudelet, Yuan Liu, Matthew Weidman, Michael E. Sigman, Martin Richardson, SciX 2012; Kansas City, MO, USA; 10/02, 2012
- 86 ***"Laser plasma sources for EUV lithography"***, M. Richardson, Photonics West 2012, San Francisco, High Power Laser materials processing, paper 8239-01
- 85 ***"Multispectral optical tweezers for molecular diagnostics of single biological cells"***, Corey Butler; Shima Fardad; Alex Sincore; Marie Vangheluwe; Matthieu Baudelet; Martin Richardson, Photonics West 2012, San Francisco, CA; Imaging, Manipulation, and Analysis of Biomolecules, Cells, and Tissues, paper 8235-13, 2012